

INTERNAL LEAKAGE (TYPICAL)

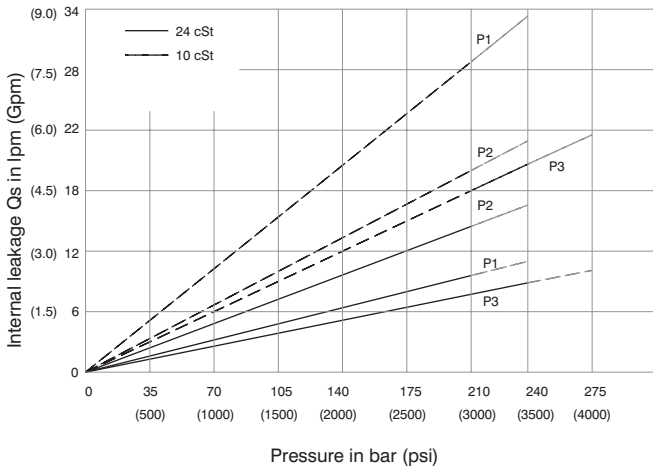

Do not operate pump more than 5 seconds at any speed or viscosity if internal leakage is more than 50% of theoretical flow. Total leakage is the sum of each section loss at its operating conditions.

NOISE LEVEL (TYPICAL)

VT7QEDC - 062-B35-022

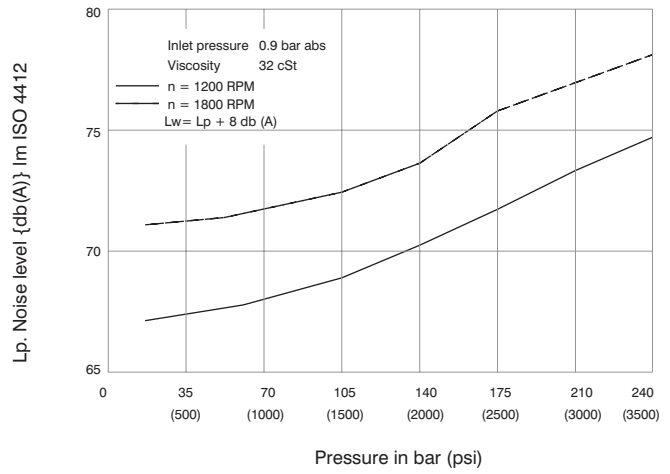

Triple pump noise level is given with each section discharging at the pressure noted on the curve.



HYDROMECHANICAL POWER LOSS (TYPICAL)

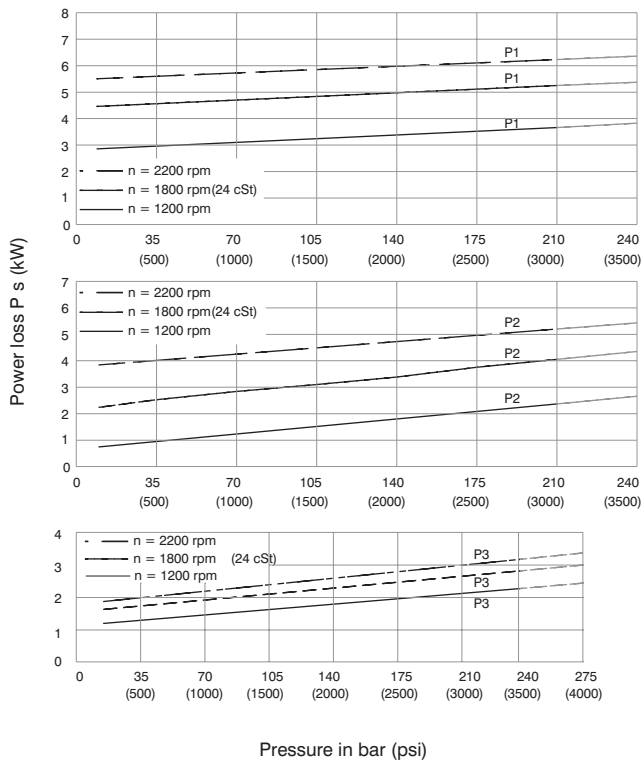

Total hydromechanical power loss is the sum of each section at its operating conditions.

PERMISSIBLE RADIAL LOAD

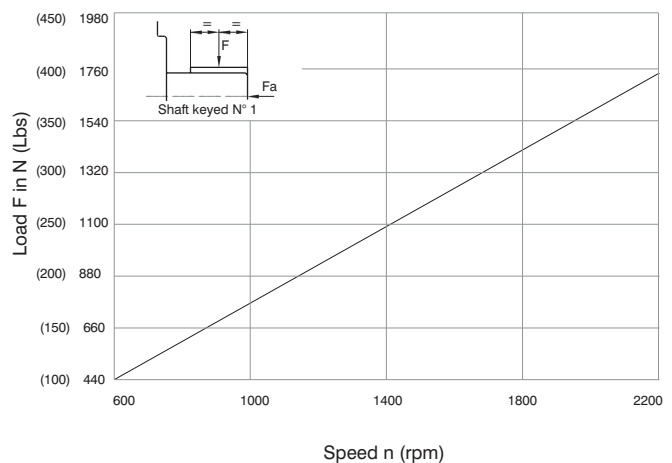

Maximum permissible axial load $F_a = 2000 \text{ N (449 Lbs)}$

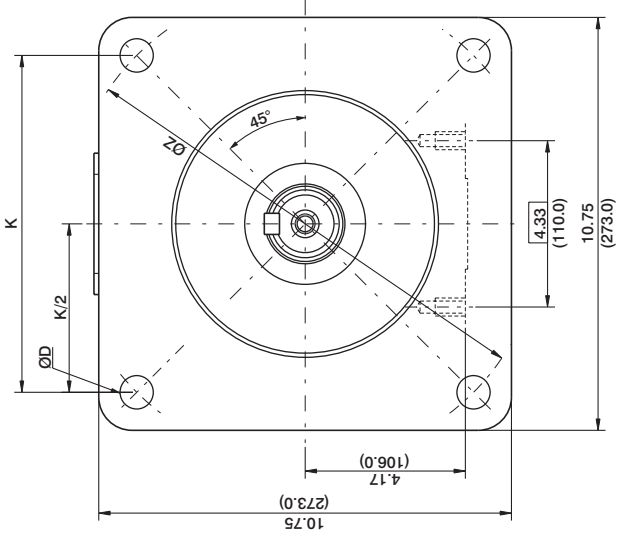
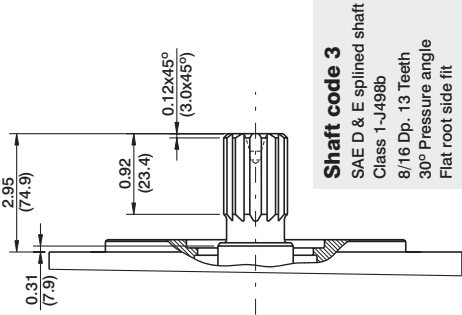
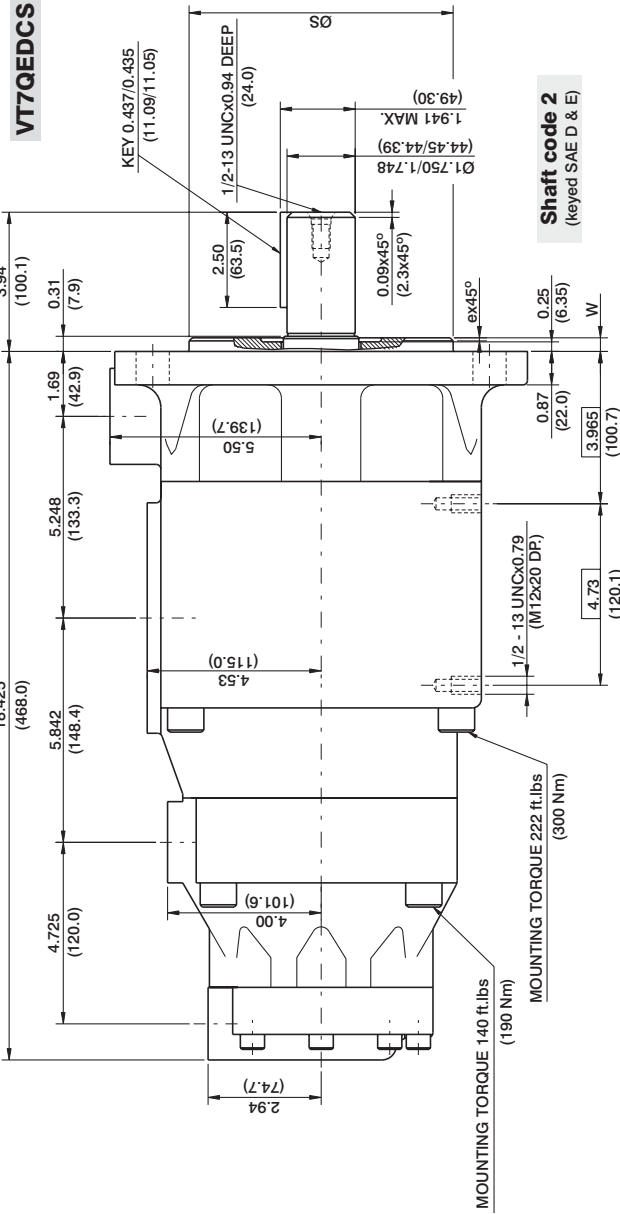
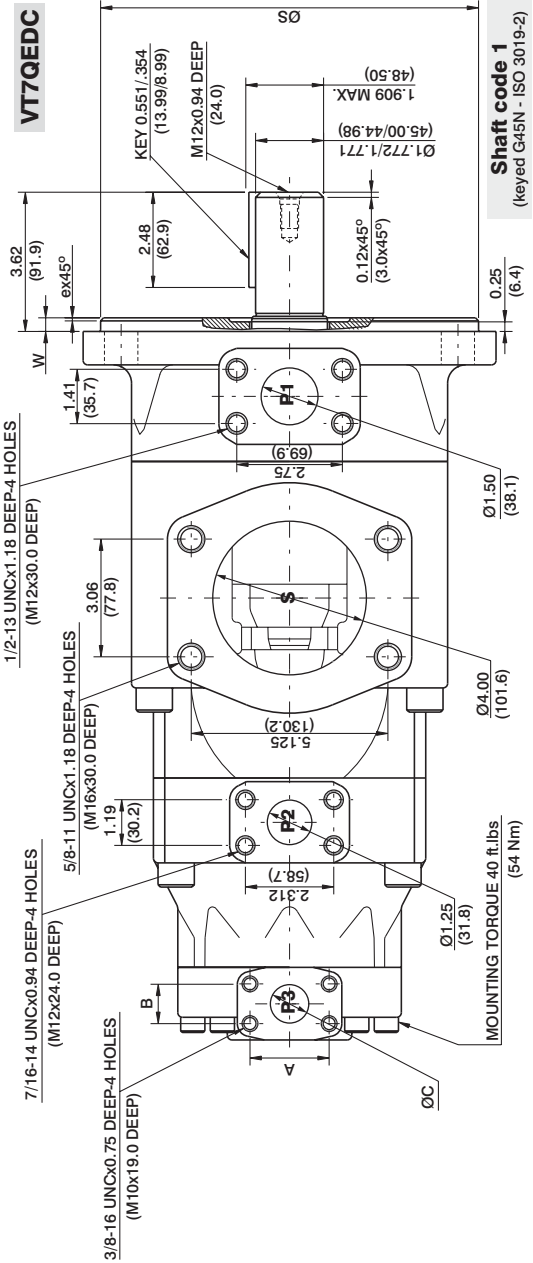

Shaft torque limits in³/rev x psi (ml/rev x bar)

Shaft	Vp x p max. (P1 + P2 + P3)
1	101506 (114715)
2	104818 (118458)
3	112312 (126928)

Alternate mounting flange

Series	ØS		W	ex45°	K	ØZ	ØD
	MAX.	Min.					
VT7QEDC	9.842 (250.0)	9.840 (249.94)	0.354 (8.99)	0.079 (2.0)	---	12.401 (315.0)	0.866 (21.99)
VT7QEDCS	6.50 (165.10)	6.498 (165.05)	0.354 (8.99)	0.079 (2.0)	8.838 (224.5)	---	0.811 (20.59)

PORT CODE	A	B	ØC
00&M0	2.06 (52.4)	1.03 (26.2)	1.00 (25.4)
01&M1	1.874 (47.6)	0.874 (22.2)	0.75 (19.0)