

## VT7EDB or VT7EDBS - 062 - B28 - B10 - 1 R 00 - A 1 - 00 \*

VT7EDB series-250 B4 HW  
ISO 4 bolts 3019-2 mounting flange  
VT7EDBS series- SAE E 4 bolts  
Mounting flange J744

### Cam ring for "P1"

Volumetric displacement cm<sup>3</sup>/rev (in<sup>3</sup>/rev)

042 = 132.2 (8.07)	057 = 183.2 (11.18)
045 = 142.5 (8.70)	062 = 196.6 (12.0)
050 = 158.5 (9.67)	066 = 213.0 (13.0)
052 = 163.8 (10.0)	072 = 227.1 (13.86)
054 = 170.9 (10.43)	085 = 268.7 (16.40)

### Cam ring for "P2"

Volumetric displacement cm<sup>3</sup>/rev (in<sup>3</sup>/rev)

B14 = 43.9 (2.68)	B31 = 99.1 (6.05)
B17 = 55.0 (3.36)	B35 = 113.4 (6.92)
B20 = 66.0 (4.03)	B38 = 120.6 (7.36)
B22 = 70.3 (4.29)	B42 = 137.5 (8.39)
B24 = 81.1 (4.95)	045 = 145.7 (8.89)
B28 = 89.9 (5.49)	050 = 157.9 (9.64)

### Cam ring for "P3"

Volumetric displacement cm<sup>3</sup>/rev (in<sup>3</sup>/rev)

B02 = 5.7 (0.35)	B08 = 24.9 (1.52)	B12 = 40.9 (2.50)
B03 = 9.8 (0.60)	B07 = 22.5 (1.37)	B14 = 45.1 (2.75)
B04 = 12.8 (0.78)	B09 = 28.0 (1.71)	B15 = 50.0 (3.05)
B05 = 15.9 (0.97)	B10 = 31.8 (1.94)	
B06 = 19.8 (1.21)	B11 = 34.9 (2.13)	

### Modifications

#### Mounting w/connection variables

4 bolts SAE flange (J518)

	P1 = 11"	P2 = 11"	S = 4"
	P3	UNC	METRIC
VT7EDB	1"		M0
VT7EDB	3/4"		M1
VT7EDBS	1"	00	M0
VT7EDBS	3/4"	01	M1

#### Seal class

- 1 - S1 (for mineral oil)
- 4 - S4 (for fire resistant fluids)
- 5 - S5 (for mineral oil and fire resistant fluids)

#### Design letter

#### Porting combination

00 = Standard

#### Direction of rotation (view on shaft end)

- R - Clockwise
- L - Counter - clockwise

#### Type of Shaft VT7EDB

- 1 - Keyed (G45N-ISO 3019-2)

#### Type of Shaft VT7EDBS

- 2 - Keyed (SAE D & E)
- 3 - Splined (SAE D & E)



### OPERATING CHARACTERISTICS - TYPICAL (24 cST) (Input power p (KW) for one cartridge only)

Pressure port	Series	Volumetric Displacement Vp		Flow q & n = 1800 rpm						Input power p & n = 1800 rpm					
		in <sup>3</sup> /rev	cm <sup>3</sup> /rev	p = 0 bar (0 psi)		p = 140 bar (2000 psi)		p = 240 bar (3500 psi)		p = 7 bar (100 psi)		p = 140 bar (2000 psi)		p = 240 bar (3500 psi)	
				gpm	lpm	gpm	lpm	gpm	lpm	hp	kw	hp	kw	hp	kw
P1	042	8.07	132.2	62.92	237.8	60.37	228.2	58.52	221.2	8.09	6.03	78.44	58.49	133.80	99.77
	045	8.70	142.5	67.72	255.9	65.17	246.3	63.32	239.3	8.37	6.24	84.04	62.66	143.60	107.08
	050	9.67	158.5	75.38	284.9	72.83	275.3	70.98	268.3	8.82	6.58	92.97	69.32	159.24	118.75
	052	10.00	163.8	78.37	296.2	75.82	286.6	73.97	279.6	8.99	6.70	96.47	71.93	165.36	123.31
	054	10.43	170.9	81.27	307.2	78.72	297.6	76.87	290.6	9.17	6.83	99.75	74.38	177.46	132.33
	057	11.18	183.2	87.12	329.3	84.57	319.7	82.72	312.7	9.51	7.09	106.57	79.46	189.84	141.56
	062	12.00	196.6	93.54	353.6	90.99	343.9	89.14	336.9	9.88	7.36	114.17	85.13	196.34	146.41
	066	13.00	213.0	101.44	383.4	98.89	373.8	97.04	366.8	10.34	7.71	123.38	92.00	212.46	158.43
	072	13.86	227.1	108.00	408.2	105.45	398.6	103.60	391.6	10.72	7.99	131.04	97.71	225.86	168.42
085	16.40	268.7	127.79	483.0	126.13 <sup>1)</sup>	476.7 <sup>1)</sup>	--	--	11.88	8.85	101.66 <sup>1)</sup>	75.80 <sup>1)</sup>	--	--	
P2				p = 0 bar (0 psi)		p = 140 bar (2000 psi)		p = 250 bar (3630 psi)		p = 7 bar (100 psi)		p = 140 bar (2000 psi)		p = 250 bar (3630 psi)	
	B14	2.68	43.9	20.92	79.1	19.18	72.5	17.81	67.3	3.46	2.6	27.77	20.7	47.03	35.07
	B17	3.36	55.0	26.16	98.8	24.41	92.3	23.04	87.0	3.77	2.8	33.88	25.3	57.71	43.03
	B20	4.03	66.0	31.39	118.6	29.64	112.0	28.27	106.8	4.07	3.0	39.98	29.8	68.39	50.99
	B22	4.29	70.3	33.43	126.4	31.69	119.8	30.32	104.6	4.19	3.1	42.37	31.6	72.57	54.12
	B24	4.95	81.1	38.57	145.8	36.82	139.2	35.45	134.0	4.49	3.4	48.36	36.1	83.06	61.93
	B28	5.49	89.9	42.80	161.8	41.06	155.2	39.69	150.0	4.74	3.5	53.30	39.7	91.70	68.38
	B31	6.05	99.1	47.18	178.3	45.43	171.7	44.06	166.5	4.99	3.7	58.41	43.6	100.63	75.03
	B35	6.92	113.4	53.93	203.9	52.18	197.2	50.81	192.0	5.39	4.0	66.29	49.4	114.42	85.32
	B38	7.36	120.6	57.35	216.8	55.61	210.2	54.24	204.9	5.59	4.2	70.28	52.4	121.42	90.54
	B42	8.39	137.5	65.39	247.2	63.65	240.6	62.28	235.4	6.05	4.5	79.66	59.4	137.83	102.77
045	8.89	145.7	69.29	262.0	67.11	253.6	65.31	246.8	6.74	5.0	83.75	62.4	145.79	108.71	
050	9.64	157.9	75.14	284.0	72.96	275.8	71.78 <sup>2)</sup>	271.3 <sup>2)</sup>	7.08	5.3	90.58	67.5	134.50 <sup>2)</sup>	100.3 <sup>2)</sup>	
P3				p = 0 bar (0 psi)		p = 140 bar (2000 psi)		p = 300 bar (4350 psi)		p = 7 bar (100 psi)		p = 140 bar (2000 psi)		p = 300 bar (4350 psi)	
	B02	0.35	5.7	2.76	10.4	2.33	8.8	1.80	6.8	0.74	0.55	4.02	2.99	8.10	6.04
	B03	0.60	9.8	4.66	17.6	4.23	15.9	3.70	14.0	0.85	0.63	6.24	4.65	12.93	9.64
	B04	0.78	12.8	6.09	23.0	5.66	21.4	5.13	19.4	0.94	0.70	7.90	5.89	16.55	12.34
	B05	0.97	15.9	7.56	28.6	7.13	26.9	6.60	25.0	1.02	0.76	9.62	7.17	20.29	15.13
	B06	1.21	19.8	9.42	35.6	8.99	33.9	8.46	32.0	1.13	0.84	11.79	8.79	25.00	18.64
	B07	1.37	22.5	10.70	40.4	10.27	38.8	9.74	36.8	1.20	0.89	13.29	9.91	28.26	21.07
	B08	1.52	24.9	11.84	44.7	11.41	43.1	10.88	41.1	1.27	0.95	14.62	10.90	31.15	23.23
	B09	1.71	28.0	13.31	50.3	12.87	48.6	12.35	47.0	1.36	1.02	16.35	12.19	34.92	26.03
	B10	1.94	31.8	15.12	57.2	14.69	55.5	14.16	53.5	1.46	1.09	18.45	13.76	39.48	29.44
	B11	2.13	34.9	16.64	62.9	16.19	61.2	15.68	59.3	1.55	1.16	20.17	15.04	43.22	32.22
	B12	2.50	40.9	19.50	73.7	19.07	72.1	18.54	70.1	1.72	1.28	23.55	17.56	50.58	37.71
	B14	2.75	45.1	21.40	80.8	20.95	79.2	20.44	77.0	1.83	1.36	25.80	19.23	55.48	41.37
	B15	3.05	50.0	23.78	89.8	23.35	88.3	22.88 <sup>3)</sup>	86.5 <sup>3)</sup>	1.97	1.47	28.55	21.28	57.35 <sup>3)</sup>	42.76 <sup>3)</sup>

1) 085 = 90 bar (1300 psi) max.int.

2) 050 = 210 bar (3000 psi) max. int

3) B15 = 280 bar (4060 psi) max. int

## INTERNAL LEAKAGE ( TYPICAL )

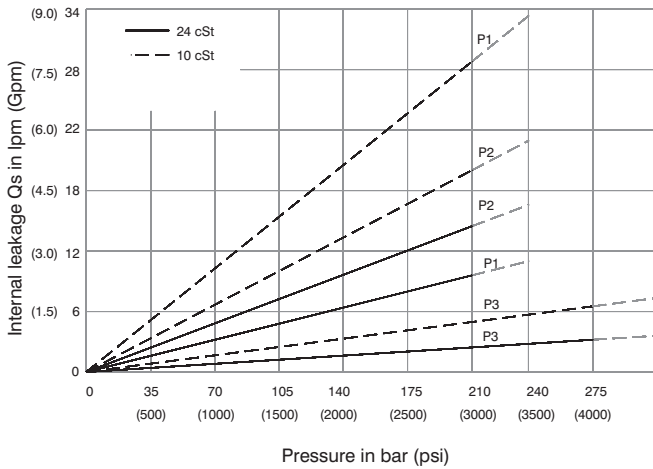

Do not operate pump more than 5 seconds at any speed or viscosity if internal leakage is more than 50% of theoretical flow. Total leakage is the sum of each section loss at its operating conditions.

## NOISE LEVEL ( TYPICAL )

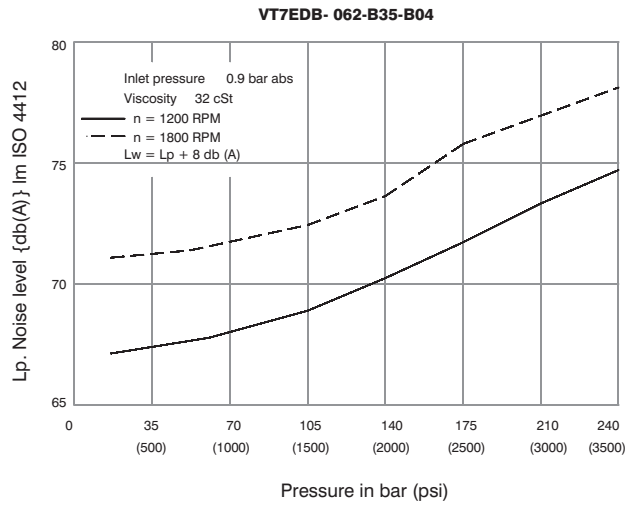

Triple pump noise level is given with each section discharging at the pressure noted on the curve.

## HYDROMECHANICAL POWER LOSS ( TYPICAL )

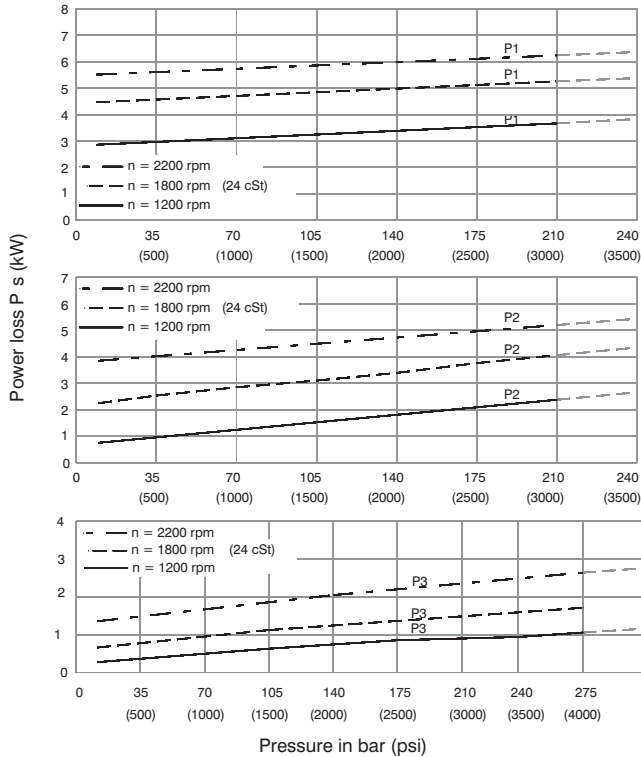

Total hydromechanical power loss is the sum of each section at its operating conditions.

## PERMISSIBLE RADIAL LOAD

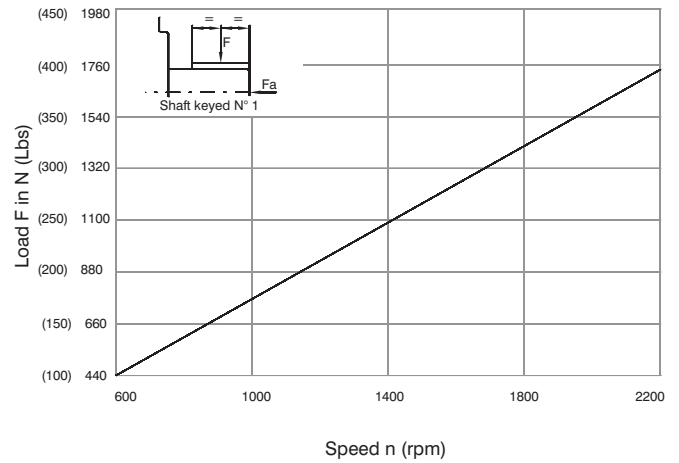

Maximum permissible axial load  $F_a = 2000$  N (449 Lbs)



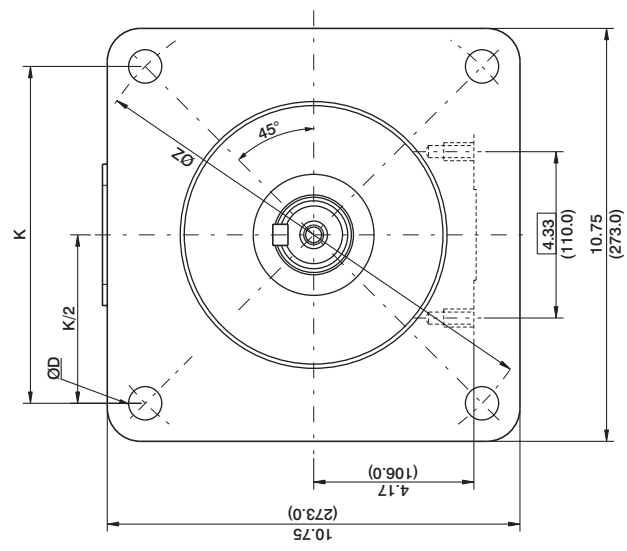
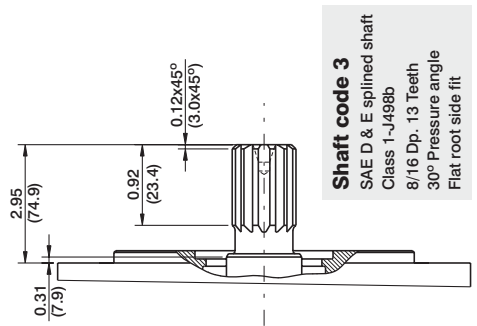
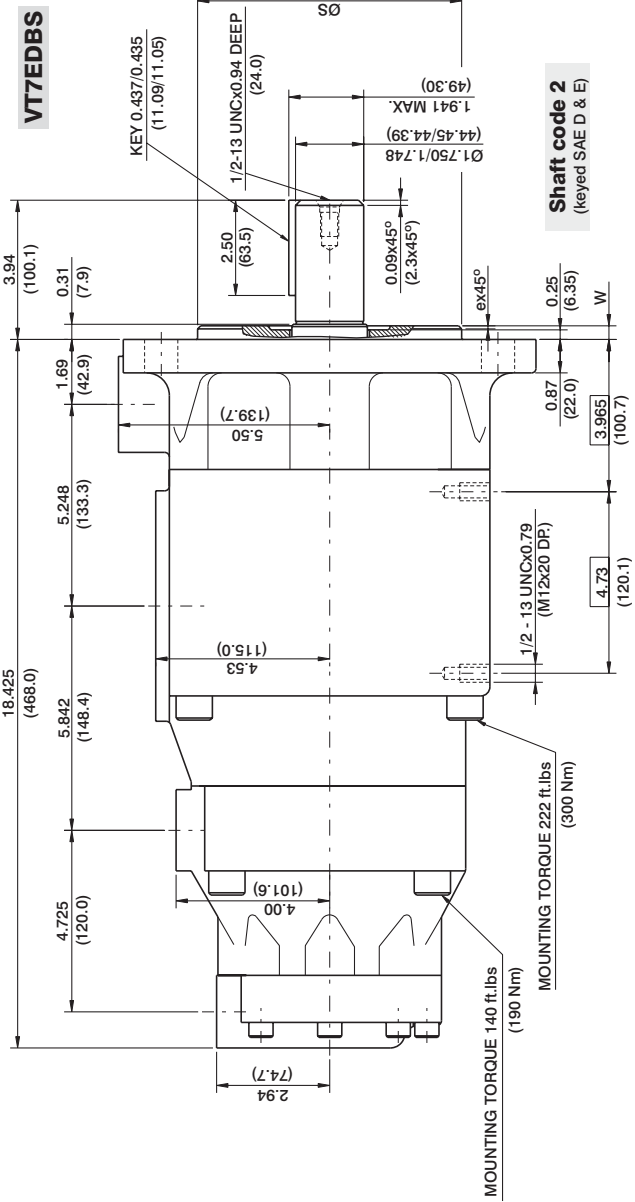
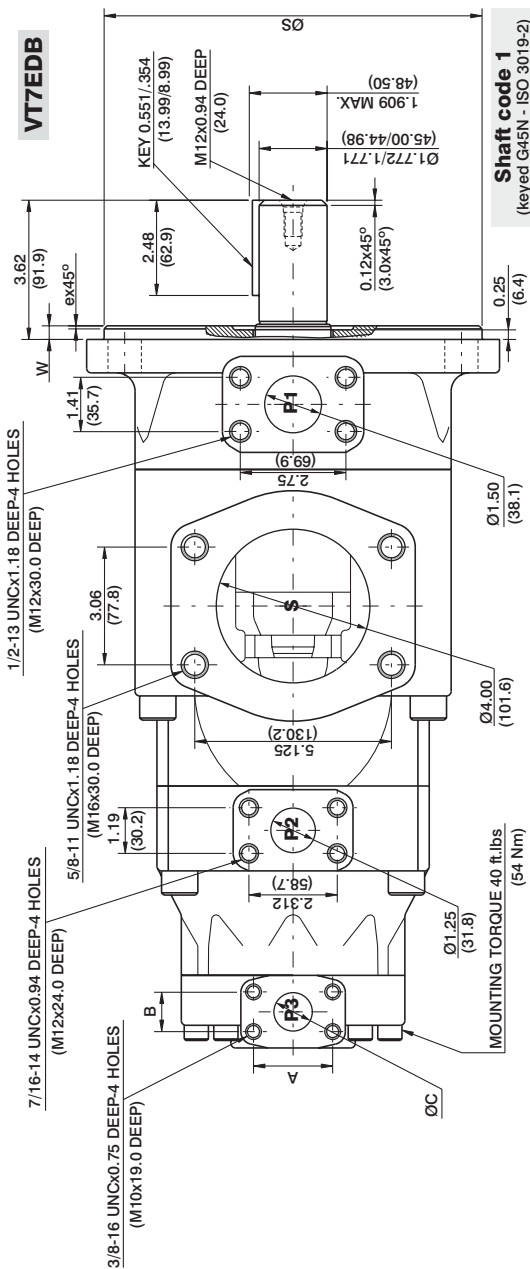

Series	ØS		W	K	Alternate mounting flange		ØD
	MAX.	Min.			ex45°	ØZ	
VT7EDB	9.842 (250.0)	9.840 (249.94)	0.079 (2.0)	0.354 (8.99)	----	12.401 (315.0)	0.866 (21.99)
VT7EDBS	6.50 (165.10)	6.498 (165.05)	0.079 (2.0)	0.354 (8.99)	8.838 (224.5)	----	0.811 (20.59)

Shaft torque limits in <sup>3</sup> /rev x psi (ml/rev x bar)	
Shaft 1	Vp x p max. (P1+P2+P3)
2	101506 (114715)
3	104818 (118458)
	112312 (126928)

PORT CODE	A	B	ØC
00&M0	2.06 (52.4)	1.03 (26.2)	1.00 (25.4)
P3	1.874 (47.6)	0.874 (22.2)	0.75 (19.0)

