

VT6DCB - 038 - 017 - B02 - 1 R 00 - B 1 01 *

Series

Cam ring for "P2"

Volumetric displacement cm³/rev (in³/rev)

*014/B14 = 47.6 (2.90)	035/B35 = 111.0 (6.77)
017/B17 = 58.2 (3.55)	038/B38 = 120.3 (7.34)
020/B20 = 66.0 (4.03)	042/B42 = 136.0 (8.30)
024/B24 = 79.5 (4.85)	045/B45 = 145.7 (8.89)
028/B28 = 89.7 (5.47)	050/B50 = 158.0 (9.64)
031/B31 = 98.3 (6.00)	061/B61 = 190.5 (11.62)

*'0' - Uni - directional 'B' - Bi - directional

Cam ring for "P2"

Volumetric displacement cm³/rev (in³/rev)

*003/B03 = 10.8 (0.66)	015/B15 = 50.5 (3.08)
005/B05 = 17.2 (1.05)	017/B17 = 58.3 (3.56)
006/B06 = 21.3 (1.30)	020/B20 = 63.8 (3.89)
008/B08 = 26.4 (1.61)	022/B22 = 70.3 (4.29)
010/B10 = 34.1 (2.08)	025/B25 = 79.3 (4.84)
012/B12 = 37.1 (2.26)	028/B28 = 88.8 (5.42)
014/B14 = 46.0 (2.81)	031/B31 = 100.0 (6.10)

*'0' - Uni - directional 'B' - Bi - directional

Cam ring for "P3"

Volumetric displacement cm³/rev (in³/rev)

B02 = 6.5 (0.39)
B03 = 8.8 (0.54)
B04 = 12.8 (0.78)
B06 = 20.7 (1.26)
B08 = 26.1 (1.59)
B09 = 31.5 (1.92)
B12 = 39.7 (2.42)

Modifications

Port connections

S=3" SAE 4-Bolt Pad
P1 = 1 1/4" & P2 = 1" SAE 4-Bolt Pad

UNC METRIC		P3
01	W0	SAE 8, 3/4" 16 UNF - 2B O'Ring Boss
11	W1	3/4" SAE 4 Bolt Pad

Seal class

- 1 - S1 (for mineral oil)
- 4 - S4 (for fire resistant fluids)
- 5 - S5 (for mineral oil and fire resistant fluids)

Design letter

Porting combination (see page CI-1-4)

00 - standard

Direction of rotation (view on shaft end)

- R - clockwise
- L - counter-clockwise

Type of Shaft

- 1 - Keyed (no SAE)
- 2 - Keyed (SAE CC)
- 3 - Splined (SAE C)
- E - Splined (SAE C)



OPERATING CHARACTERISTICS - TYPICAL (24 cST) (Input power p (KW) for one cartridge only)

Pressure port	Series	Volumetric Displacement Vp		Flow q & n = 1500 rpm						Input power p & n = 1500 rpm					
		in ³ /rev	cm ³ /rev	p = 0 bar (0 psi)		p = 140 bar (2000 psi)		p = 240 bar (3500 psi)		p = 7 bar (100 psi)		p = 140 bar (2000 psi)		p = 240 bar (3500 psi)	
				gpm	lpm	gpm	lpm	gpm	lpm	hp	kw	hp	kw	hp	kw
P1	014	2.90	47.6	18.88	71.4	16.42	62.1	14.78	55.9	3.08	2.3	24.81	18.5	41.03	30.6
	017	3.55	58.2	23.1	87.3	20.6	78.0	18.99	71.8	3.35	2.5	29.77	22.2	49.62	37.0
	020	4.00	66.0	26.19	99.0	23.73	89.7	22.08	83.5	3.75	2.8	33.39	24.9	55.92	41.7
	024	4.80	79.5	31.56	119.3	29.10	110.0	27.46	103.8	4.02	3.0	39.69	29.6	66.78	49.8
	028	5.50	89.7	35.58	134.5	33.12	125.2	31.48	119.0	4.29	3.2	44.52	33.2	74.96	55.9
	031	6.00	98.3	39.00	147.5	36.53	138.1	34.89	131.9	4.42	3.3	48.54	36.2	81.80	61.0
	035	6.80	111.0	44.04	166.5	41.58	157.2	39.94	151.0	4.69	3.5	54.58	40.7	92.13	68.7
	038	7.30	120.3	47.72	180.4	45.26	171.1	43.62	164.9	4.96	3.7	58.87	43.9	99.64	74.3
	042 ¹⁾	8.30	136.0	53.96	204.0	51.50	194.7	49.86	188.5	5.36	4.0	66.25	49.4	112.24	83.7
	045 ¹⁾	8.89	145.7	57.80	218.5	55.34	209.2	53.70	203.0	5.50	4.1	70.81	52.8	120.02	89.5
	050 ¹⁾	9.64	158.0	62.69	237.0	60.23	227.7	59.25 ²⁾	224.0 ²⁾	5.90	4.4	76.44	57.0	113.98 ²⁾	85.0 ²⁾
061 ¹⁾	11.62	190.5	76.25	285.7	73.54 ³⁾	278.0 ³⁾	--	--	6.16	4.6	81.26 ³⁾	60.6 ³⁾	--	--	
P2	003	0.66	10.8	4.29	16.2	2.96	11.2	2.04	7.7	1.74	1.3	7.11	5.3	11.22	8.4
	005	1.05	17.2	6.83	25.8	5.50	20.8	4.57	17.3	1.88	1.4	10.06	7.5	16.36	12.2
	006	1.30	21.3	8.44	31.9	7.11	26.9	6.19	23.4	2.01	1.5	11.94	8.9	19.71	14.7
	008	1.61	26.4	10.48	39.6	9.15	34.6	8.22	31.1	2.15	1.6	14.35	10.7	22.93	17.7
	010	2.08	34.1	13.52	51.1	12.19	46.1	11.26	42.6	2.28	1.7	18.64	13.4	29.90	22.3
	012	2.26	37.1	14.71	55.6	13.36	50.6	12.46	47.1	2.28	1.7	19.31	14.4	32.32	24.1
	014	2.81	46.0	18.25	69.0	16.93	64.0	16.00	60.5	2.55	1.9	23.60	17.6	39.56	29.5
	015	3.08	50.5	20.00	75.6	18.73	73.2	19.02	67.5	2.68	2.0	25.61	19.1	42.91	32.0
	017	3.56	58.3	23.12	87.4	21.79	82.4	20.87	78.9	2.82	2.1	29.37	21.9	49.48	36.9
	020	3.89	63.8	25.32	95.7	23.99	90.7	23.07	87.2	2.95	2.2	31.92	23.8	53.91	40.2
	022	4.29	70.3	27.88	105.4	26.56	100.4	25.63	96.9	3.08	2.3	35.00	26.1	59.14	44.1
	025	4.84	79.3	31.46	118.9	30.13	113.9	29.21	110.4	3.35	2.5	39.16	29.2	66.38	49.5
	028	5.42	88.8	35.24	133.2	33.92	128.2	33.28 ²⁾	125.8 ²⁾	3.75	2.8	43.85	32.7	65.04 ²⁾	48.5 ²⁾
031	6.10	100.0	39.68	150.0	38.35	145.0	37.72 ²⁾	142.6 ²⁾	3.75	2.8	48.95	36.5	72.95 ²⁾	54.4 ²⁾	
P3				p = 0 bar (0 psi)	p = 100 bar (1500 psi)	p = 240 bar (3000 psi)	p = 7 bar (100 psi)	p = 100 bar (1500 psi)	p = 240 bar (3000 psi)						
	B02	0.39	6.5	2.64	10.0	2.11	8.0	-	-	0.53	0.4	2.81	2.1	-	-
	B03	0.54	8.8	3.49	13.2	2.96	11.2	2.43	9.2	0.67	0.5	3.62	2.7	7.11	5.3
	B04	0.78	12.8	5.08	19.2	4.55	17.2	4.02	15.2	0.93	0.7	5.23	3.9	10.06	7.5
	B06	1.26	20.7	8.20	31.0	7.67	29.0	7.14	27.0	1.07	0.8	8.05	6.0	12.34	9.2
	B08	1.59	26.1	10.34	39.1	9.78	37.0	9.25	35.0	1.34	1.0	10.05	7.5	15.69	11.7
	B09	1.92	31.5	12.48	47.2	11.93	45.1	11.42	43.2	1.47	1.1	11.94	8.9	23.60	17.6
	B12	2.42	39.7	15.74	59.5	15.18	57.4	14.68	55.5	1.74	1.3	15.02	11.2	29.50	22.0

1) 042-045-050-061=2200 RPM max.

2) 028-031-050=210 bar (3000 psi) max.

3) 061 = 120 bar (1740 psi) max. int, 061 = 80 bar (1160 psi) cont.

- Not to use because internal leakage greater than 50% of theoretical flow

INTERNAL LEAKAGE (TYPICAL)

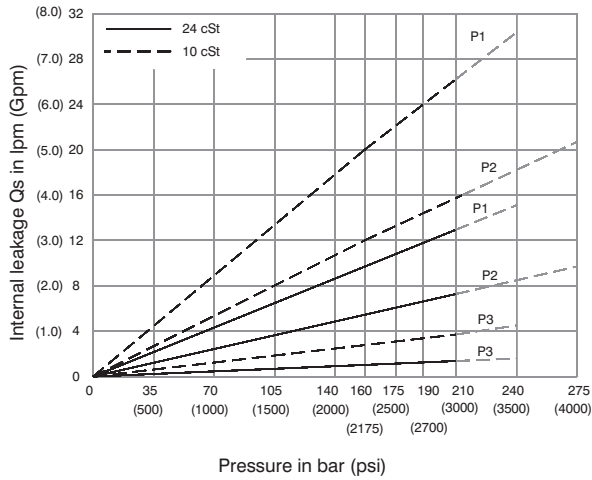

Don not operate pump more than 5 seconds at any speed or viscosity if internal leakage is more than 50% of theoretical flow.
Total leakage is the sum of each section loss at its operating conditions.



HYDROMECAHNNICAL POWER LOSS (TYPICAL)

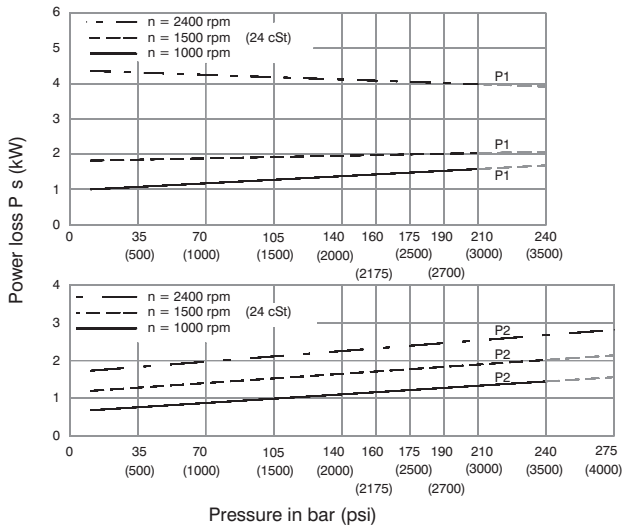

Total hydromechanical power loss is the sum of each section at its operating conditions.

PERMISSIBLE RADIAL LOAD

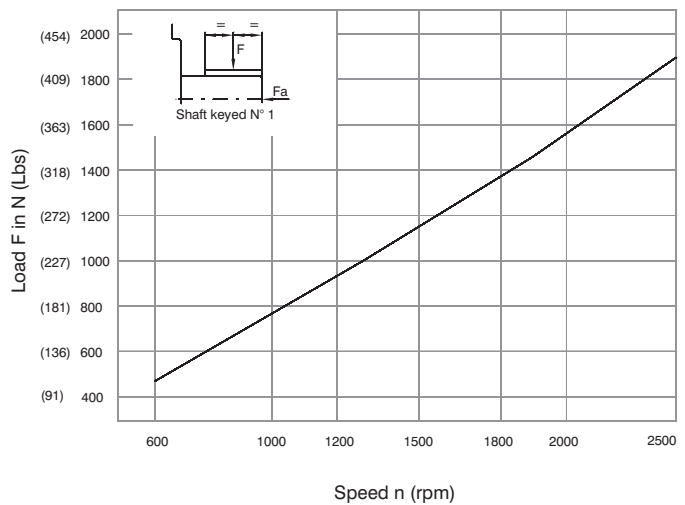

Maximum permissible axial load $F_a = 1200$ N (270 Lbs)

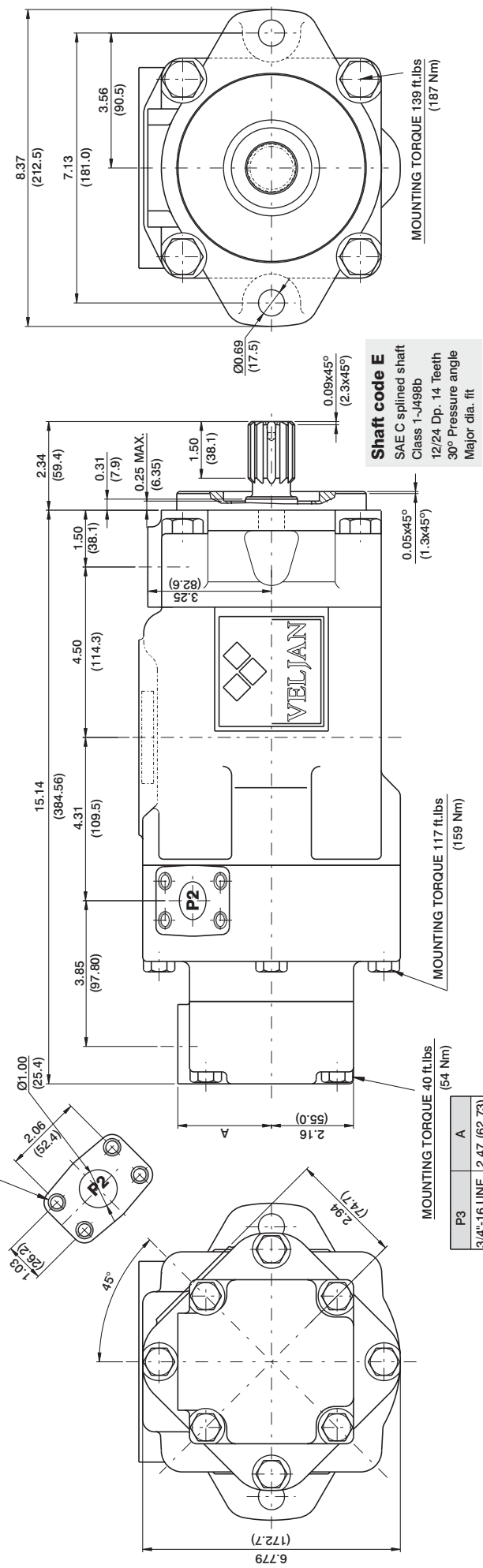
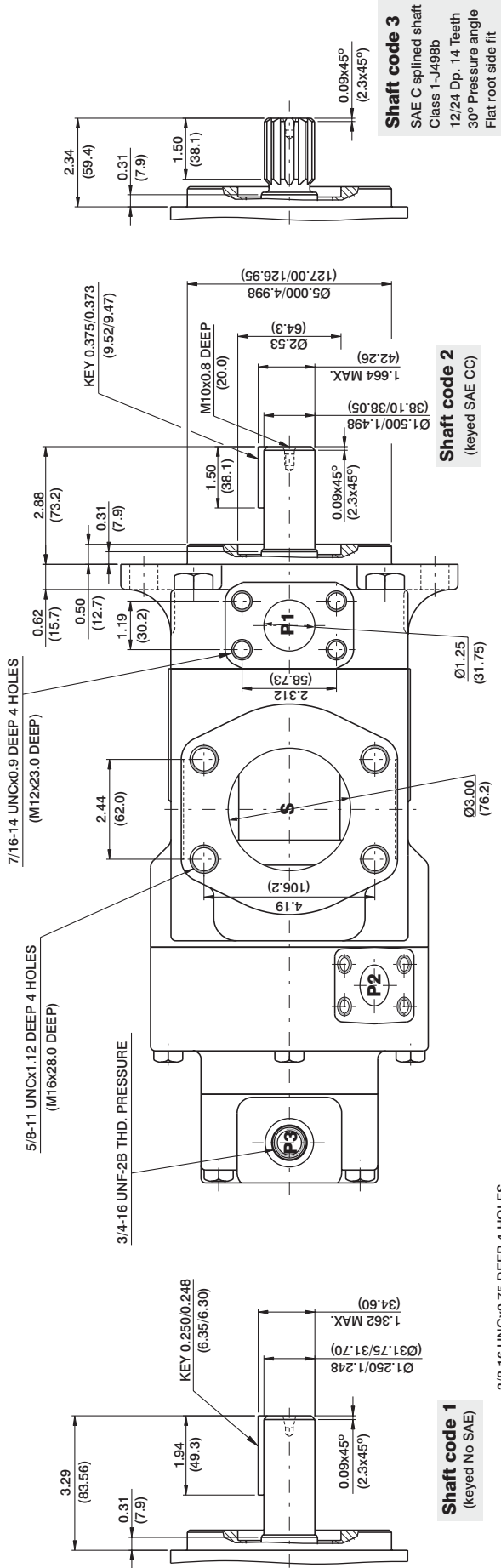

	P3	A
3/4"-16 UNF	2.47 (62.73)	
3/4" SAE PAD	2.75 (69.8)	