

VT6GCC - B22 - B08 - 6 R 00 - A 1 - 00 *

Series

P1 P2

Cam ring "P1" & "P2"

Volumetric displacement cm³/rev (in³/rev)

B03 = 10.8 (0.66)	B15 = 50.5 (3.08)
B05 = 17.2 (1.05)	B17 = 58.3 (3.56)
B06 = 21.3 (1.30)	B20 = 63.8 (3.89)
B08 = 26.4 (1.61)	B22 = 70.3 (4.29)
B10 = 34.1 (2.08)	B25 = 79.3 (4.84)
B12 = 37.1 (2.26)	B28 = 88.8 (5.42)
B14 = 46.0 (2.81)	B31 = 100.0 (6.10)

Type of shaft

6 - splined (DIN 5462)

Direction of rotation (view on shaft end)

R - clockwise

L - counter-clockwise

Modifications

Mounting W/connection variables

		P1=1"-S=3"		P1=1"-S=2 1/2" ⁽¹⁻²⁾		
		P2	1"	3/4" ⁽¹⁾	1"	3/4" ⁽¹⁾
code	Unc	00	01	10	11	
	Metric	0M	M0	1M	M1	

- 1) for 46 ml/rev. max.
- 2) for 126 ml/rev max.

The large cartridge must be always mounted in the front.

Seal class

1 - S1

Design letter

Porting combination (see page BM-1-5)

00 - standard

INTERNAL LEAKAGE (TYPICAL)

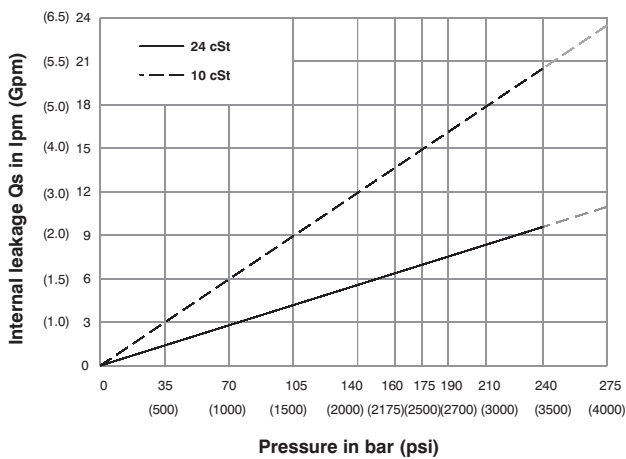

Do not operate pump more than 5 seconds at any speed or viscosity if internal leakage is more than 50% of theoretical flow. Total leakage is the sum of each section loss at its operating conditions.

NOISE LEVEL (TYPICAL)

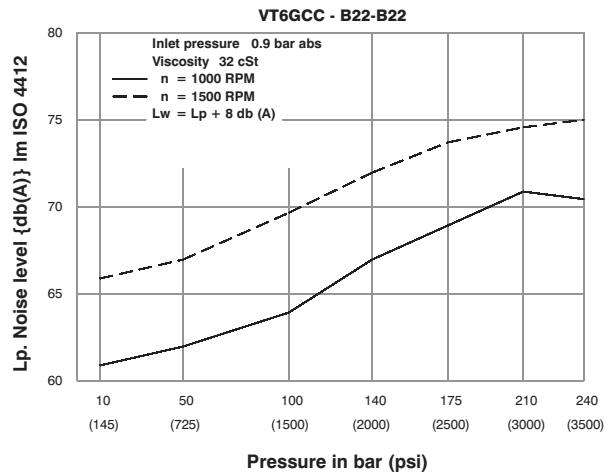

Double pump noise level is given with each section discharging at the pressure noted on the curve.

HYDROMECHANICAL POWER LOSS (TYPICAL)

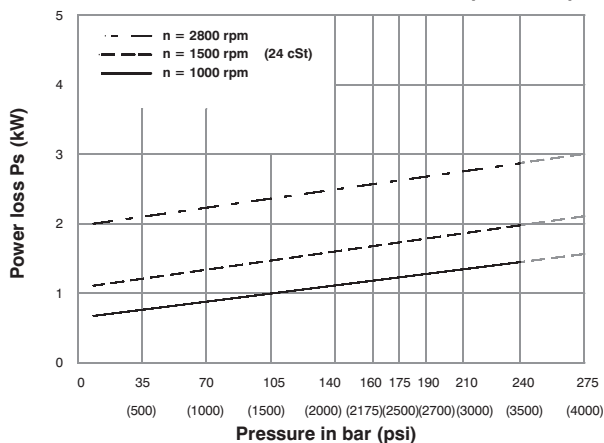

Total hydromechanical power loss is the sum of each section at its operating conditions.

PERMISSIBLE RADIAL LOAD

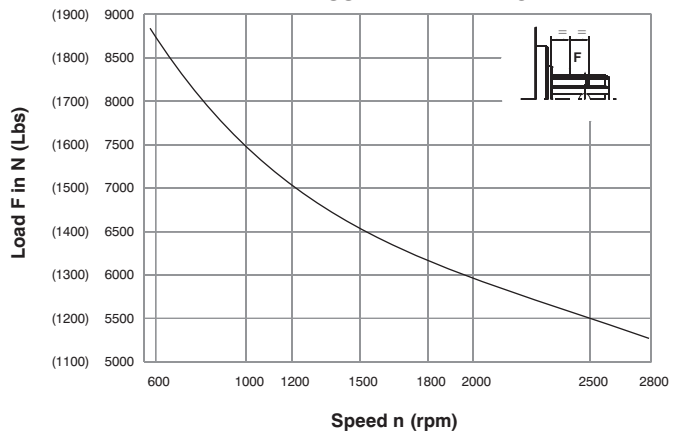

Life time 3000 hours when 70% of the time at 500 N and 30% at max. load.

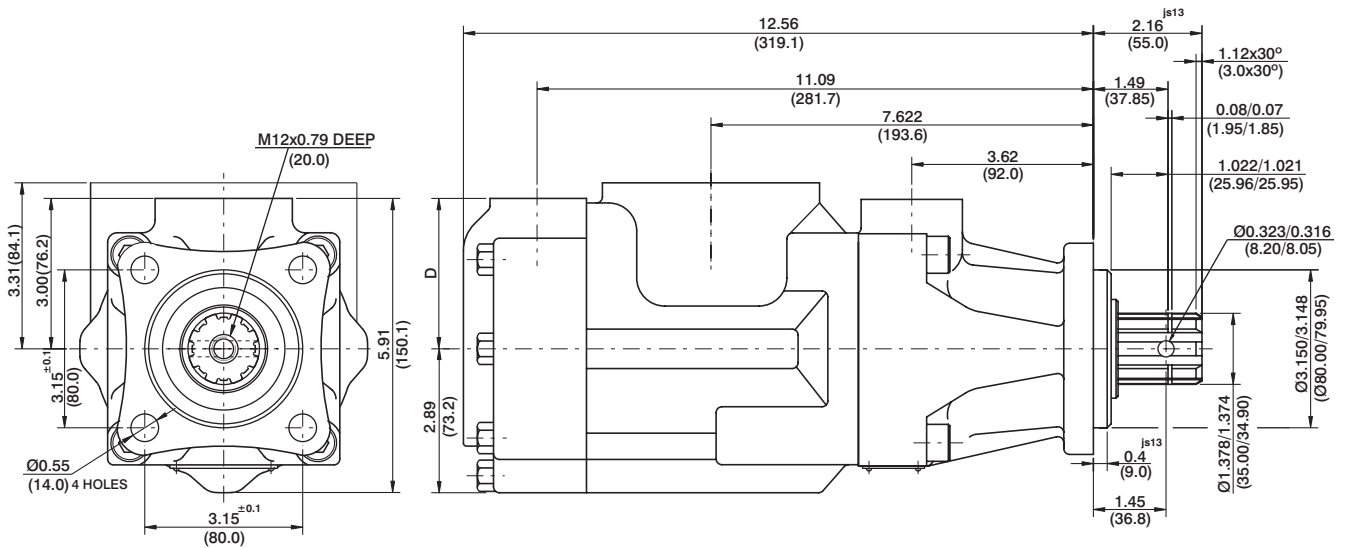
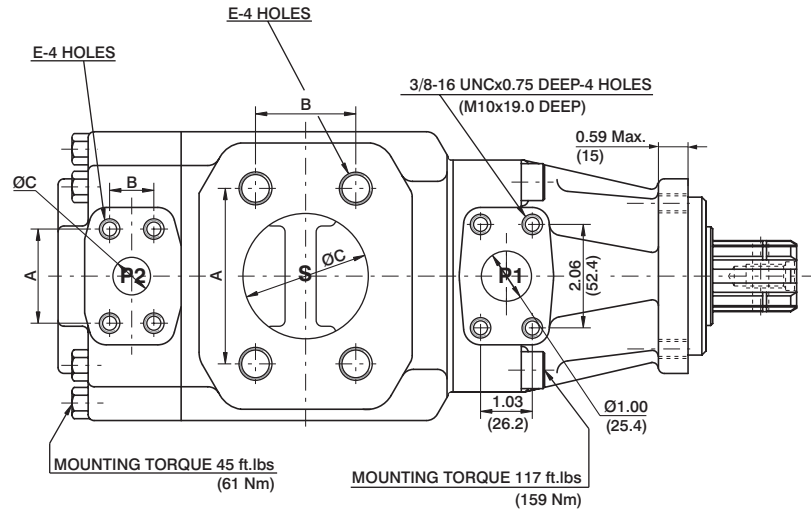

Shaft Code - 6
DIN5462B8x32x36

PORT	A	B	C	D	E
S	4.19 (106.4)	2.44 (61.9)	3.00 (76.2)		5/8-11UNCx1.12 DEEP (M16 x 28.4 DEEP)
S	3.50 (88.9)	2.00 (50.8)	2.50 (63.5)		1/2-13UNCx0.94 DEEP (M12 x 24.0 DEEP)
P2	1.88 (47.7)	0.88 (22.2)	0.75 (19.0)	3.00 (76.2)	3/8-16UNCx0.75 DEEP (M10x19.0 DEEP)
P2	2.06 (52.4)	1.03 (26.2)	1.00 (25.4)	2.94 (74.7)	

Shaft torque limits in ³ /rev x psi (ml/rev x bar)	
Shaft	Vp x p max. (P1+P2)
6	36921 (32670)

OPERATING CHARACTERISTICS - TYPICAL (24 cST) (Input power p (KW) for one cartridge only)

Pressure port	Series	Volumetric Displacement Vp		Flow q & n = 1500 rpm						Input power p & n = 1500 rpm					
				p = 0 bar (0 psi)		p = 140 bar (2000 psi)		p = 240 bar (3500 psi)		p = 7 bar (100 psi)		p = 140 bar (2000 psi)		p = 240 bar (3500 psi)	
		in ³ /rev	cm ³ /rev	gpm	lpm	gpm	lpm	gpm	lpm	hp	kw	hp	kw	hp	kw
P1 & P2	B03	0.66	10.8	4.29	16.2	2.83	10.7	--	--	1.74	1.3	7.11	5.3	--	--
	B05	1.05	17.2	6.83	25.8	5.37	20.3	4.17	15.8	1.88	1.4	10.06	7.5	16.36	12.2
	B06	1.30	21.3	8.44	31.9	7.01	26.5	5.82	22.0	2.01	1.5	11.94	8.9	19.71	14.7
	B08	1.61	26.4	10.48	39.6	9.02	34.1	7.83	29.6	2.15	1.6	14.35	10.7	22.93	17.7
	B10	2.08	34.1	13.52	51.1	12.08	45.7	10.89	41.2	2.28	1.7	18.64	13.4	29.90	22.3
	B12	2.26	37.1	14.71	55.6	13.28	50.2	12.08	45.7	2.28	1.7	19.31	14.4	32.32	24.1
	B14	2.81	46.0	18.25	69.0	16.79	63.5	15.60	59.0	2.55	1.9	23.60	17.6	39.56	29.5
	B15	3.08	50.5	20.00	75.6	18.62	70.4	17.46	66.0	2.68	2.0	25.61	19.1	42.91	32.0
	B17	3.56	58.3	23.12	87.4	21.69	82.0	20.50	77.5	2.82	2.1	29.37	21.9	49.48	36.9
	B20	3.89	63.8	25.32	95.7	23.86	90.2	22.67	85.7	2.95	2.2	31.92	23.8	53.91	40.2
	B22	4.29	70.3	27.88	105.4	26.45	100.0	25.26	95.5	3.08	2.3	35.00	26.1	59.14	44.1
	B25 ¹⁾	4.84	79.3	31.46	118.9	30.02	113.5	28.83	109.0	3.35	2.5	39.16	29.2	66.38	49.5
	B28 ¹⁾	5.42	88.8	35.24	133.2	33.78	127.7	32.93 ²⁾	124.5 ²⁾	3.75	2.8	43.85	32.7	65.04 ²⁾	48.5 ²⁾
B31 ¹⁾	6.10	100.0	39.68	150.0	38.22	144.5	37.38 ²⁾	141.3 ²⁾	3.75	2.8	48.95	36.5	72.95 ²⁾	54.4 ²⁾	

1) B25-B28-B31 = 2500 R.P.M. max.

2) B28-B31 = 210 bar (3000 psi) max. int.

-- Not to use because internal leakage greater than 50% theoretical flow.