

J9V045

AXIAL PISTON PUMP

ORDERING CODE:



VELJAN

Axial piston pump

Variable displacement,

Swash plate design,
Working pressure 280 bar.
Peak pressure 350 bar.

Size

Displacement, Vgmax 45 cc/rev

Control devices

- CP - Pressure control
- CPR - Pressure control (Remote controlled)
- CPF - Pressure and flow control
- CPFR - Pressure and flow control - X Port Closed
- CPFH - Pressure, flow and power control.

Rotation

- Viewed from shaft end
- R - Clockwise
- L - Counter clockwise

Seals

- N: NBR- (Buna-N) gasket / Shaft seal FPM
- F: FPM gasket / Shaft seal FPM

Shaft end

- 1 - Keyed shaft (DIN 6885) Ø 25
- 2 - Splined shaft 25-4 (SAE B-B, 1", 15 T)
- 3 - Splined shaft 22-4 (SAE B, 7/8", 13 T)

Mounting flange

- A-ISO (2 bolt)
- B-SAE (2 bolt)

Port connections

- M1 - SAE side ported, Metric threads
- S1 - SAE side ported, UNC threads
- M2 - SAE rear ported, Metric threads
- S2 - SAE rear ported, UNC threads

**UNIT DIMENSIONS OF J9V045
SIDE PORTED (ISO & SAE VERSIONS)**

SHAFT END DETAILS :

SHAFT '1' :

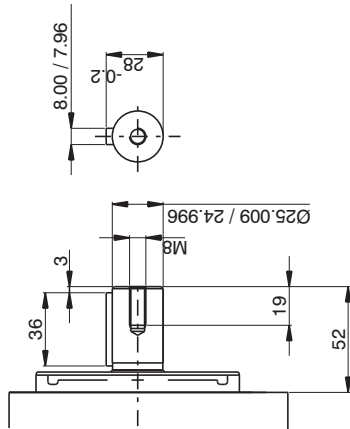

SHAFT '2' :

SHAFT 25 - 4 (SAE B-B)
SAE J744 JUNE 96
16/32 PITCH, 15 T
PRESSURE ANGLE 30°

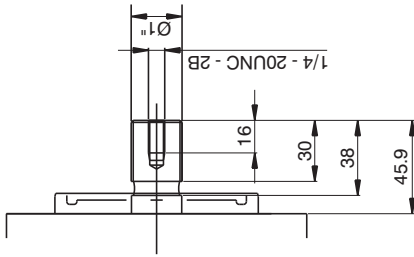

SHAFT '3' :

SHAFT 22 - 4 (SAE B)
SAE J744 JUNE 96
16/32 PITCH, 13 T
PRESSURE ANGLE 30°

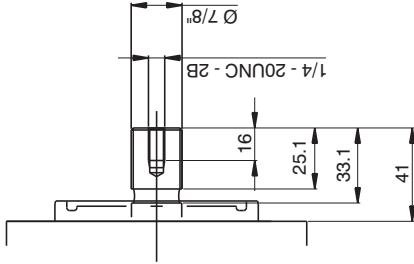

TABLE - 1 : OUTLET PORT

SIZE	OUTLET PORT	
	ISO	SAE
A	Ø25	Ø25
B	52.4	52.4
C	26.2	26.2
D	M10 X 17 depth	3/8 - 16 UNC - 2B 18 depth
PORT CONNECTIONS	SAE 1"	SAE 1"

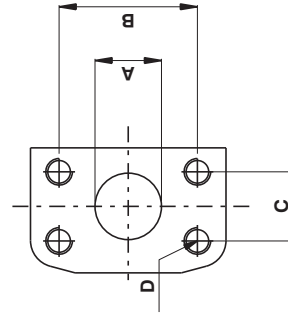

TABLE - 3 : FLANGE DETAILS

VERSION	IDENTIFICATION CODE	SPIGOT DIAMETER	SPIGOT LENGTH	PCD. OF SLOTS
ISO	3019 / 2 2 BOLT FLANGE	Ø100.000 / Ø99.946	10	Ø140
SAE	101-2(B) SAE J 744 JUN'96 4 BOLT FLANGE	Ø101.600 / Ø101.546	9.5	Ø146

TABLE - 2 : INLET PORT

SIZE	INLET PORT	
	ISO	SAE
A	Ø40	Ø40
B	69.9	69.9
C	35.7	35.7
D	M12 X 20 depth	1/2 - 13 UNC - 2B 22 depth
PORT CONNECTIONS	SAE 1 1/2"	SAE 1 1/2"

TABLE - 4 : DRAIN PORTS:-

VERSION	D1 CASE DRAIN PORT	D2 CASE DRAIN PORT (PLUGGED AT FACTORY)
ISO	M22 x 1.5	M22 x 1.5
SAE	7/8 - 14 UNF - 2B	7/8 - 14 UNF - 2B

**UNIT DIMENSIONS OF J9V045
SIDE PORTED (ISO & SAE VERSIONS)
(NOT INCLUDING VALVES) :**

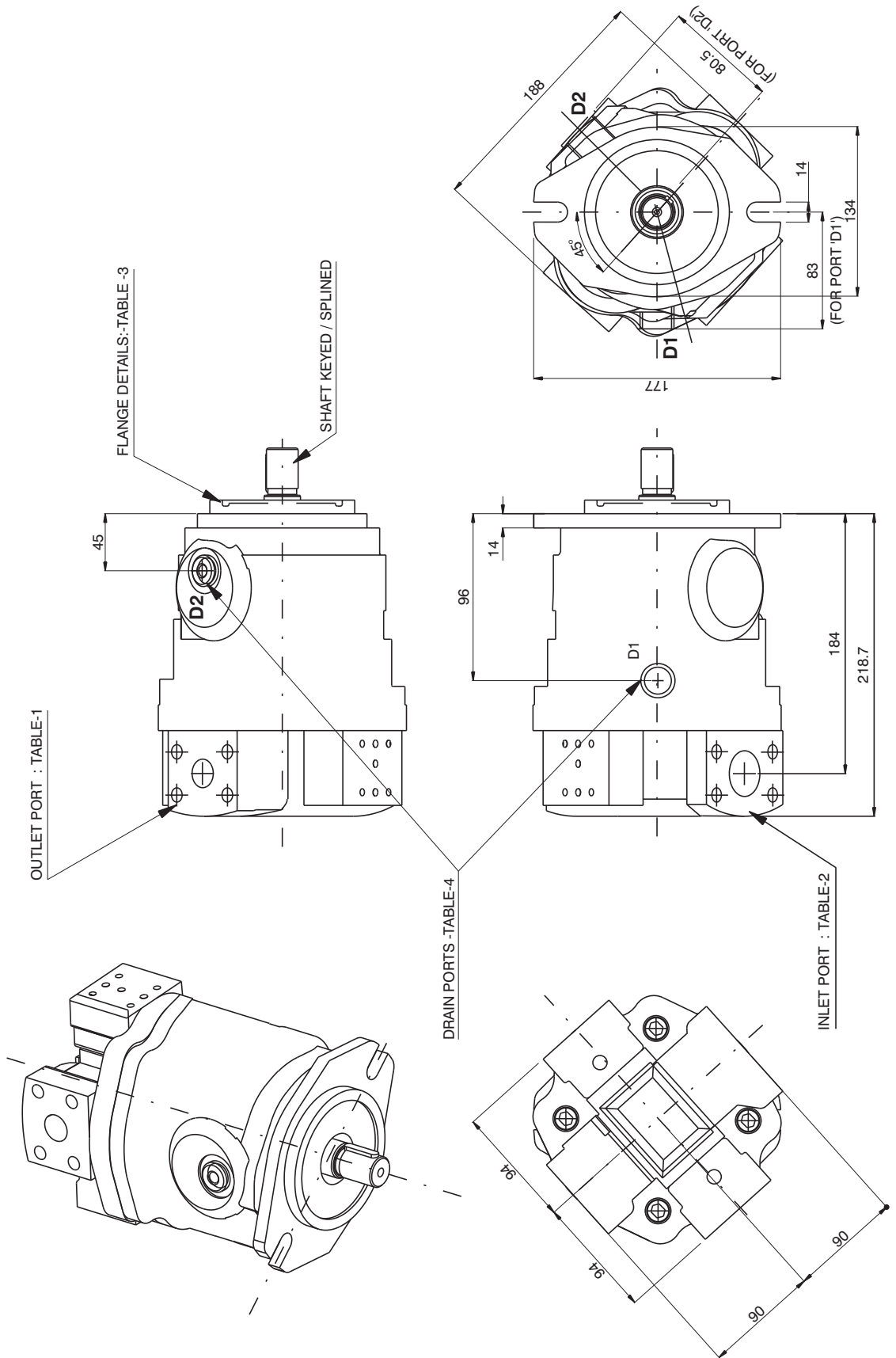

UNIT DIMENSIONS OF J9V045 REAR PORTED (ISO & SAE VERSIONS)

SHAFT END DETAILS :

SHAFT '1' :

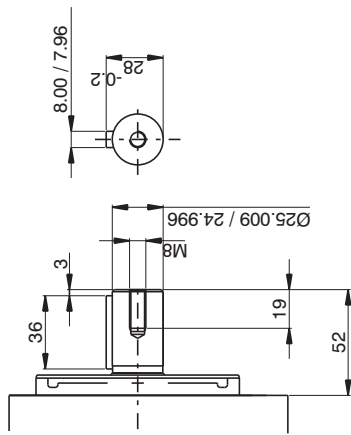

SHAFT '2' :

SHAFT 25 - 4 (SAE B-B)
SAE J744 JUNE 96
16/32 PITCH, 15 T
PRESSURE ANGLE 30°

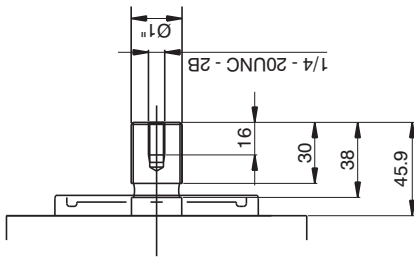

SHAFT '3' :

SHAFT 22 - 4 (SAE B)
SAE J744 JUNE 96
16/32 PITCH, 13 T
PRESSURE ANGLE 30°

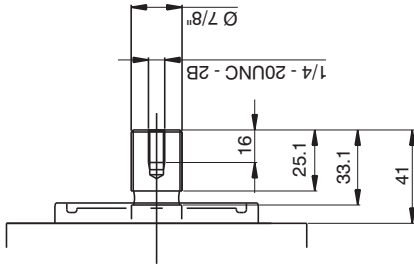

TABLE - 1 : OUTLET PORT

SIZE	OUTLET PORT	
	ISO	SAE
A	Ø25	Ø25
B	52.4	52.4
C	26.2	26.2
D	M10 X 17 depth	3/8 - 16 UNC - 2B 18 depth
PORT CONNECTIONS	SAE 1"	SAE 1"

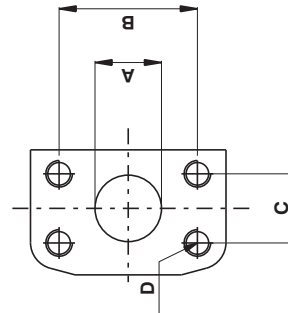

TABLE - 3 : FLANGE DETAILS

VERSION	IDENTIFICATION CODE	SPIGOT DIAMETER	SPIGOT LENGTH	PCD. OF SLOTS
ISO	3019 / 2 2 BOLT FLANGE	Ø100.000 / Ø99.946	10	Ø140
SAE	101-2(B) SAE J 744 JUN'96 4 BOLT FLANGE	Ø101.600 / Ø101.546	9.5	Ø146

TABLE - 2 : INLET PORT

SIZE	INLET PORT	
	ISO	SAE
A	Ø40	Ø40
B	69.9	69.9
C	35.7	35.7
D	M12 X 20 depth	1/2 - 13 UNC - 2B 22 depth
PORT CONNECTIONS	SAE 1 1/2"	SAE 1 1/2"

TABLE - 4 : DRAIN PORTS:-

VERSION	D1 CASE DRAIN PORT	D2 CASE DRAIN PORT (PLUGGED AT FACTORY)
ISO	M22 x 1.5	M22 x 1.5
SAE	7/8 - 14 UNF - 2B	7/8 - 14 UNF - 2B

**UNIT DIMENSIONS OF J9V045
REAR PORTED (ISO & SAE VERSIONS)
(NOT INCLUDING VALVES) :**

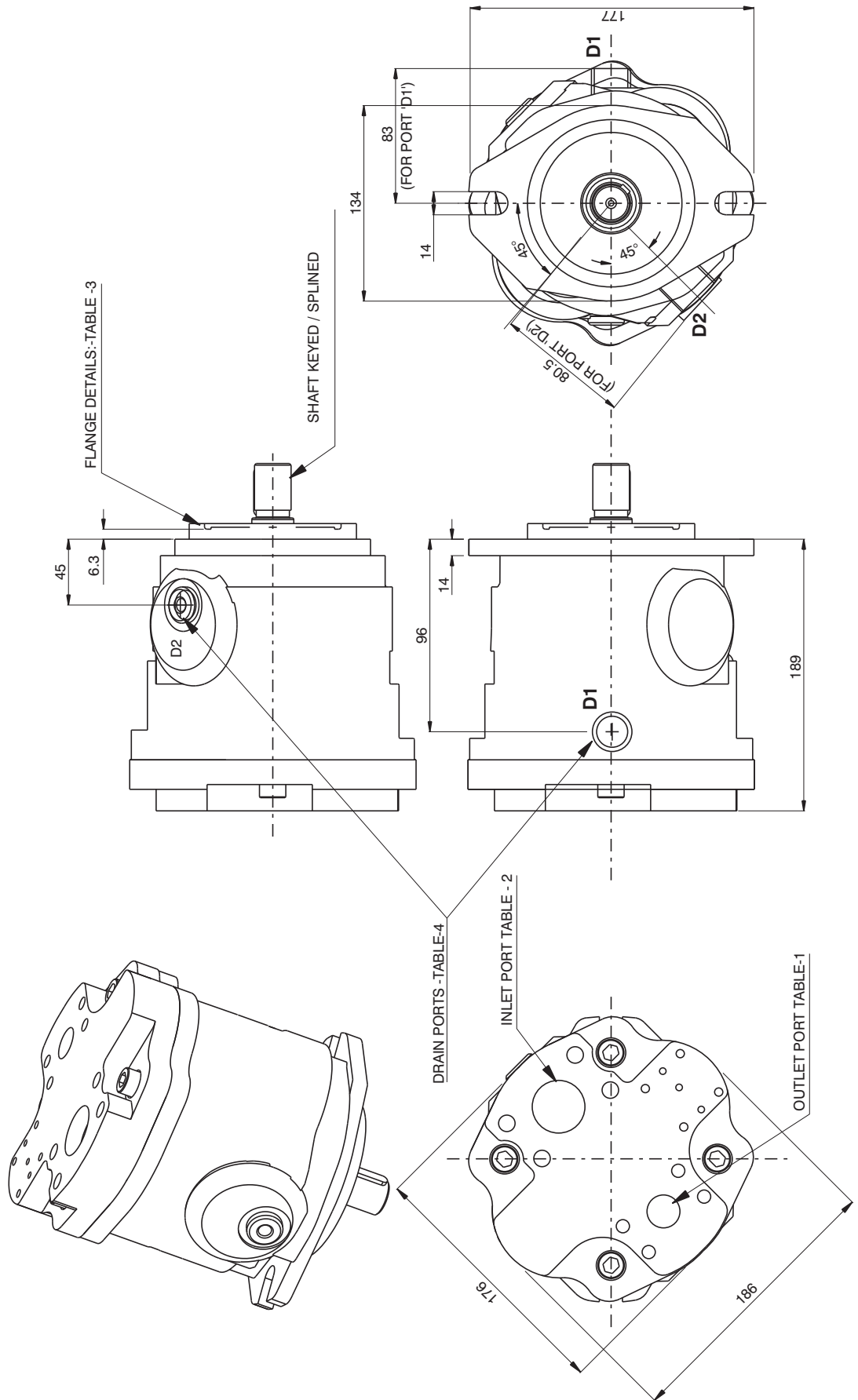

PERFORMANCE CURVES WITH PRESSURE CONTROL CP :

NOISE LEVEL VERSES OPERATING PRESSURE WITH FLUID ISO VG 46 DIN 51519 AT TEMP, t = 50°C

Measuring error: ± 2dB (A)

At n=1500 rpm

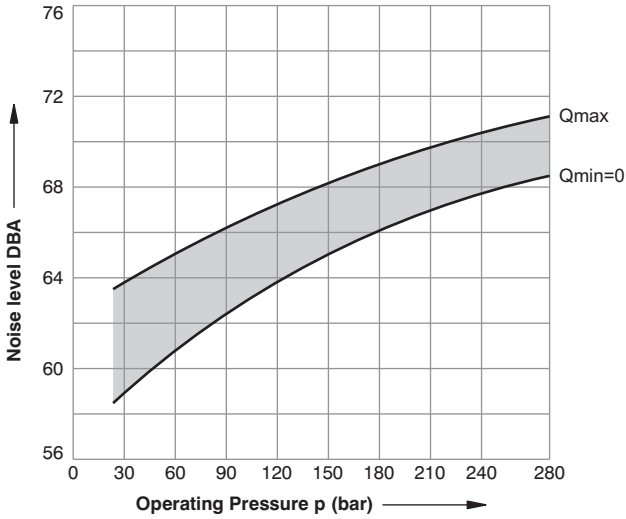

At n=2600 rpm

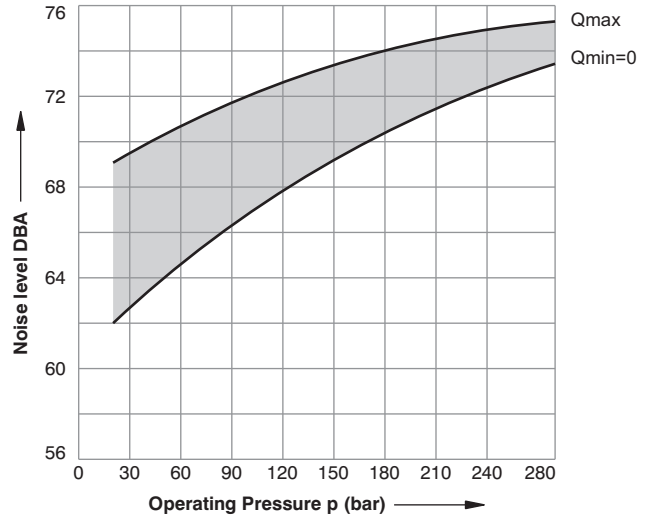

DRIVE POWER AND OUTPUT FLOW WITH HYDRAULIC FLUID ISO VG 46 DIN 51519 AT TEMP, t = 50°C

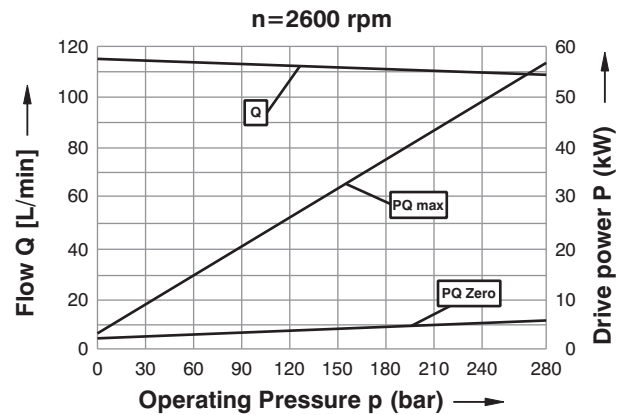
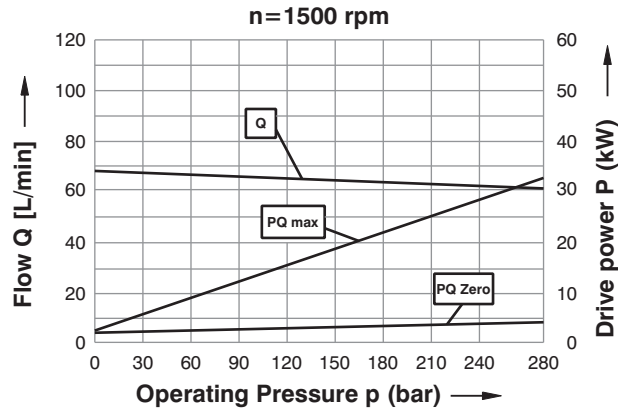

CONTROLS

The J9V 045 model piston pump is offered with a variety of control options that are designed for optimum performance of the pump in different types of applications.

CONSTANT PRESSURE CONTROL (CP)

This control maintains the pressure in a hydraulic circuit at a constant set value within the control range during pump operation irrespective of changing flow demands of the load on the pump. The pump supplies only that much volume of oil as required by the load. If the pressure in the circuit tends to raise above the set value, then the pump swash plate angle is proportionally reduced which in turn reduces the flow of oil to the load and thus preventing the pressure raise. In the starting condition when supply pressure is zero the control spring positions the swash plate at its maximum angle allowing the pump to supply the maximum volume of oil to the load in the circuit. As the pressure in circuit raises, the swash plate angle is progressively reduced by the control piston resulting in lesser oil flow to the circuit. It is further possible to restrict the min. and max. angles of the swash plate by adjustable set screws for limiting the pump flow to 50% of its max. rating. As it is possible to set the pressure control at a pressure higher than the maximum rated pressure of the pump it is recommended that an additional pressure relief valve (set to about 20 bar more than the maximum allowed control pressure) be used in the circuit.

Also to ensure that the pressure control is not set for higher than the permissible value, help of a pressure gauge mounted on the pump outlet side be considered

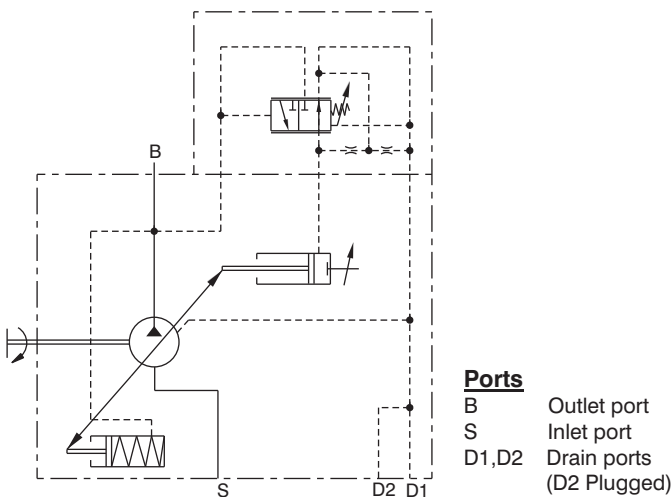

Requirement of oil approx. 3 L/min (max)

STATIC CURVE

At Speed 1500 rpm and Temperature of oil at 50° C

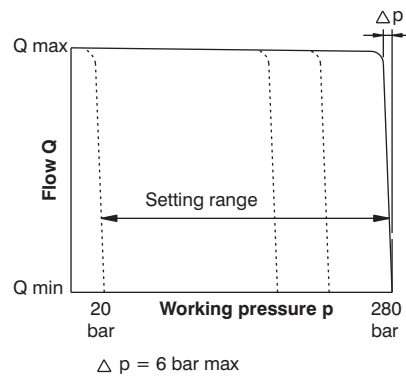

DYNAMIC OPERATING CURVES:

These curves are obtained under conditions with the unit mounted inside the tank. By opening and closing the pressure relief valve load steps can be obtained. At Speed = 1500 rpm and temperature of oil is 50°C the dynamic curves are:

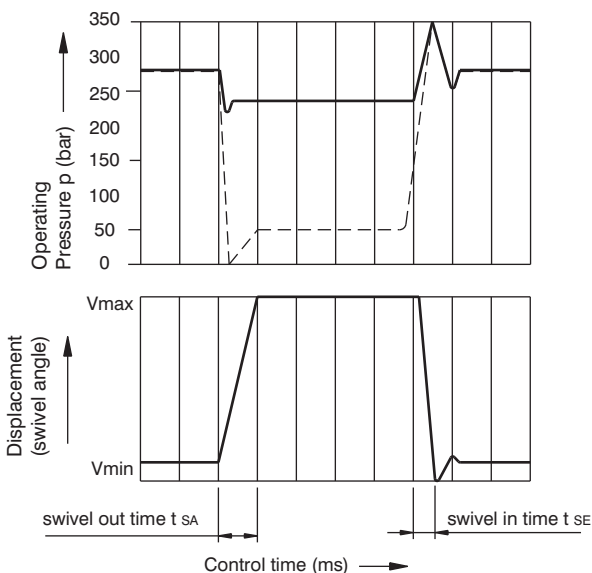

Control time:

- t_{SA} at 50 bar (725 psi) is 80 ms
- t_{SA} at 220 bar (3200 psi) is 40 ms
- t_{SE} at 280 bar (zero stroke) is 20 ms

UNIT DIMENSIONS OF CP :

SIDE PORTED :

ISO & SAE VERSIONS :

PILOT VALVE INSTALLED
HERE FOR COUNTER
CLOCKWISE DIRECTION

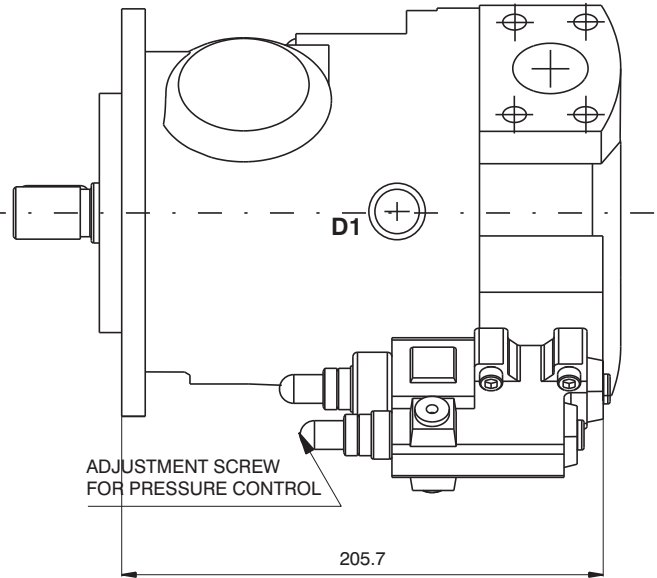
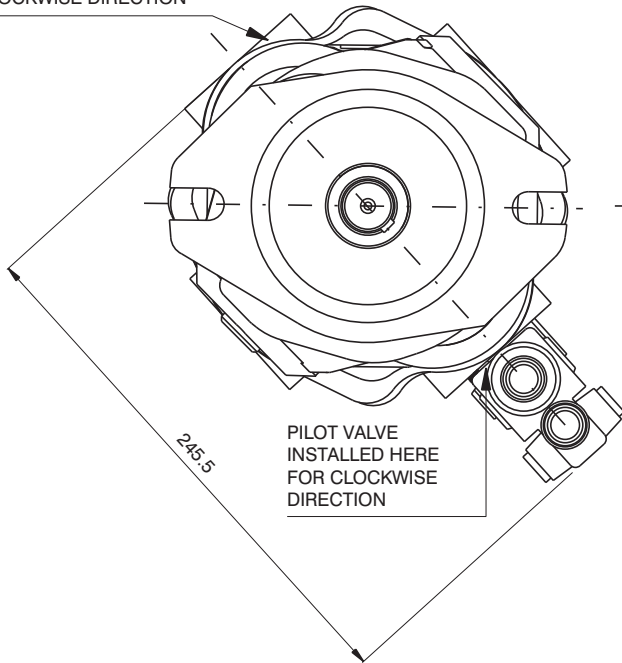

REAR PORTED :

ISO & SAE VERSIONS :

PILOT VALVE INSTALLED
HERE FOR COUNTER
CLOCKWISE DIRECTION

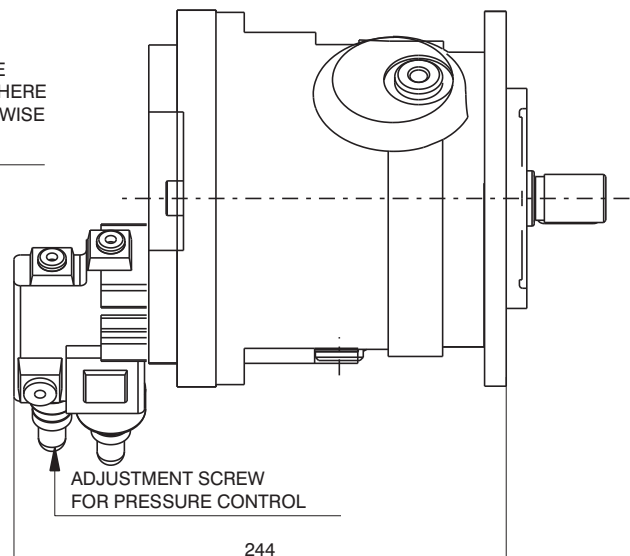
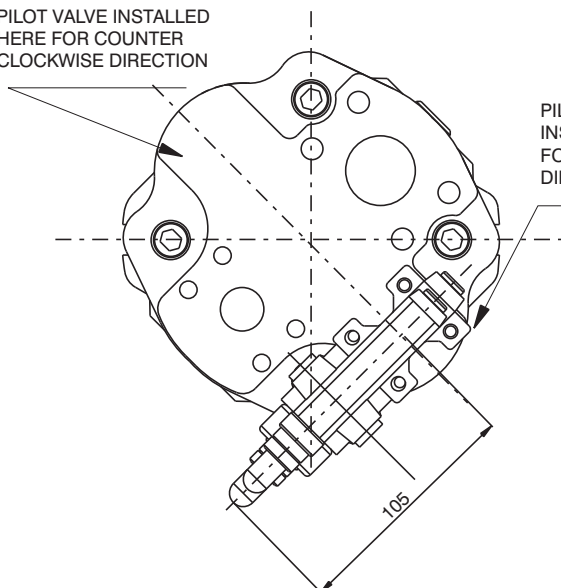

CONTROLS

CONSTANT PRESSURE CONTROL-REMOTELY SET (CPR)

This is same as above Constant Pressure Control except that in this a remotely mounted pressure relief valve is used as shown in the circuit along side for pressure setting of the pump.

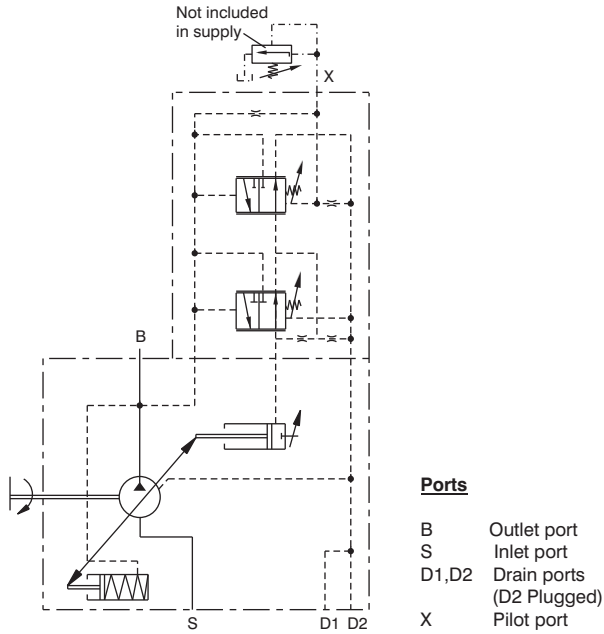

Requirement of pilot oil approx. 4.5 L/min (max) at 20 bar

STATIC CURVE

At Speed 1500 rpm and Temperature of oil at 50° C

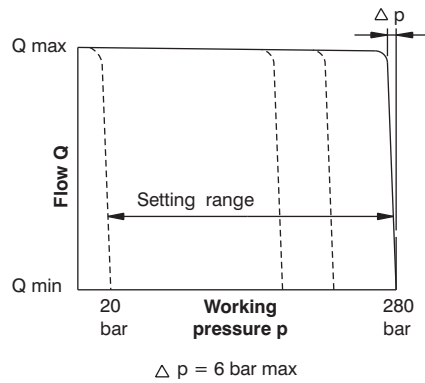

UNIT DIMENSIONS OF CPR :

SIDE PORTED :

ISO & SAE VERSIONS :

PILOT VALVE INSTALLED
HERE FOR COUNTER
CLOCKWISE DIRECTION

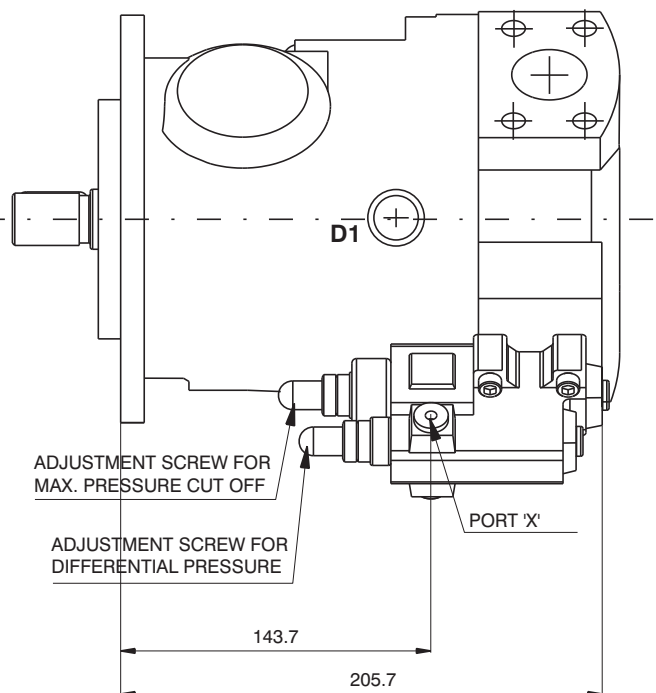
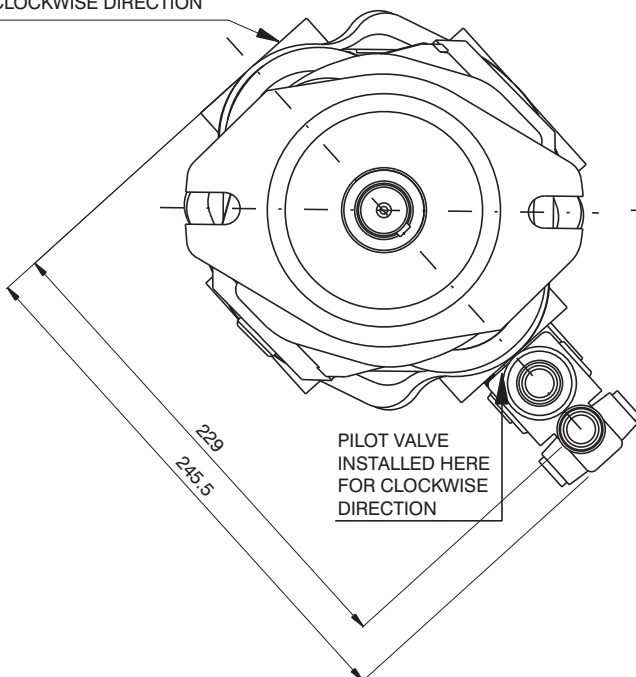

REAR PORTED :
ISO & SAE VERSIONS :

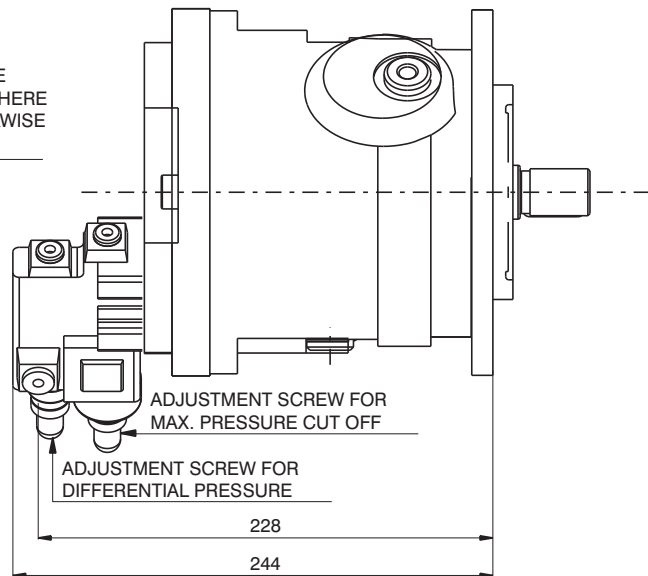
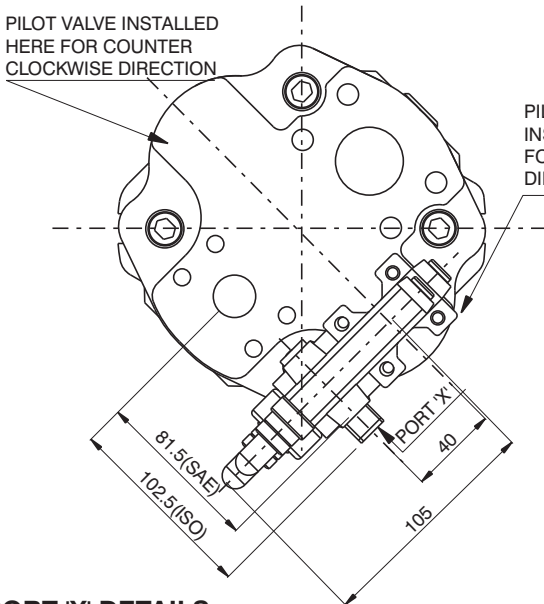

PORT 'X' DETAILS:-

ISO : M14x1.5 ; 12 DEPTH
 SAE : 7/16 -20 UNF - 2B ; 10 DEPTH

PRESSURE & FLOW CONTROL (CPF / CPFR)

PRESSURE & FLOW CONTROL (CPF) – LOAD SENSING :

In addition to the constant pressure control this also maintains constant flow to the load. The pump flow is determined by an external orifice (not part of pump control block) fitted in the circuit between the pump and the load as long as the load pressure is less than the set pressure. The differential pressure at the external orifice is used to regulate the pump displacement to match the load requirement . The pressure drop across the orifice is maintained constant and there by achieving constant flow to the load. If the differential pressure across the orifice tends to increase then the swash plate is swivelled to minimum angle reducing the pump flow and if the pressure differential is reducing then the swash plate is swivelled to the maximum angle increasing the pump flow to load. These corrections go on continuously until a balance is restored in at the flow control orifice. A bleed down orifice is provided at the control valve to vent the trapped pressure in the load sense line.

PRESSURE & FLOW CONTROL - X PORT CLOSED (CPFR)

This is same as above valve (CPF) except that it has no bleed orifice connecting the load sense line to tank

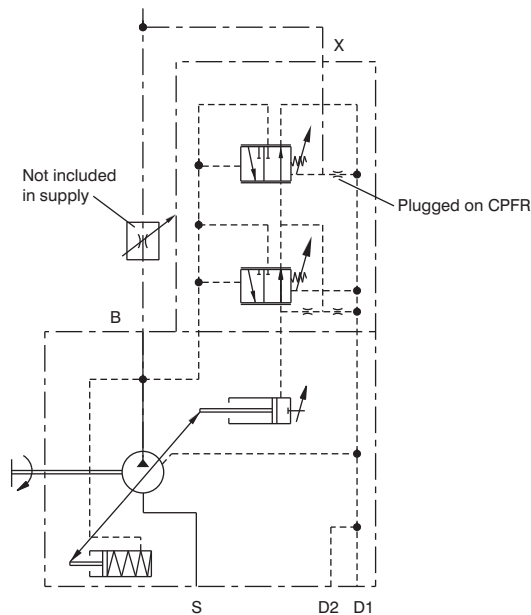

PORTS:

- B : Outlet port
- S : Inlet port
- D1,D2 : Drain ports (D2 plugged)
- X : Pilot port

STATIC CURVE

At Speed 1500 rpm and Temperature of oil at 50° C

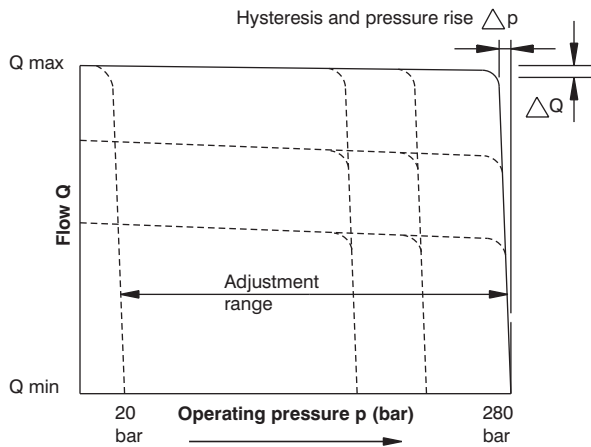

STATIC CURVE

At different Speeds

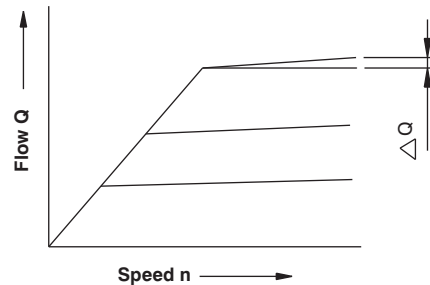

Max. flow deviation, Q_{max} is 1.8 L/min

Requirement of pilot oil for CPF ~ 4.5 L/min. (max)

Requirement of pilot oil for CPFR ~3 L/min. (max)

DYNAMIC OPERATING CURVE:

This curve is obtained under conditions with the unit mounted inside the tank.

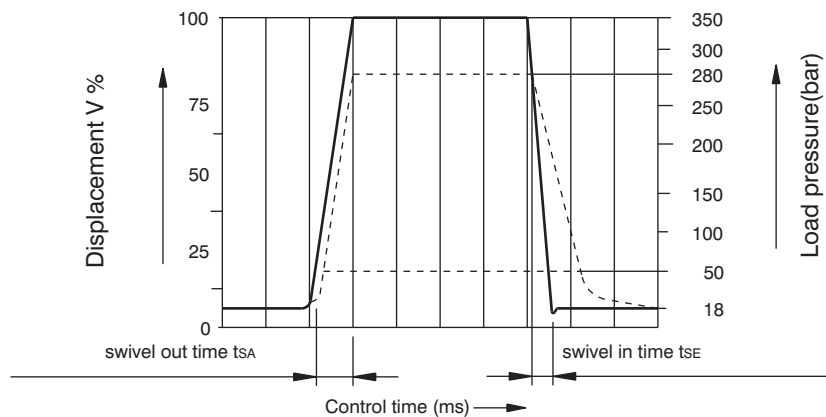

Control time:

t_{SA} at 250 bar (4000 psi) is 50 ms

t_{SE} at 250 bar stand by (4000 psi stand by) is 25 ms

t_{SE} at 50 bar stand by (725 psi stand by) is 50 ms

UNIT DIMENSIONS OF CPF / CPFR:

SIDE PORTED:

ISO & SAE VERSIONS:

PILOT VALVE INSTALLED
HERE FOR COUNTER
CLOCKWISE DIRECTION

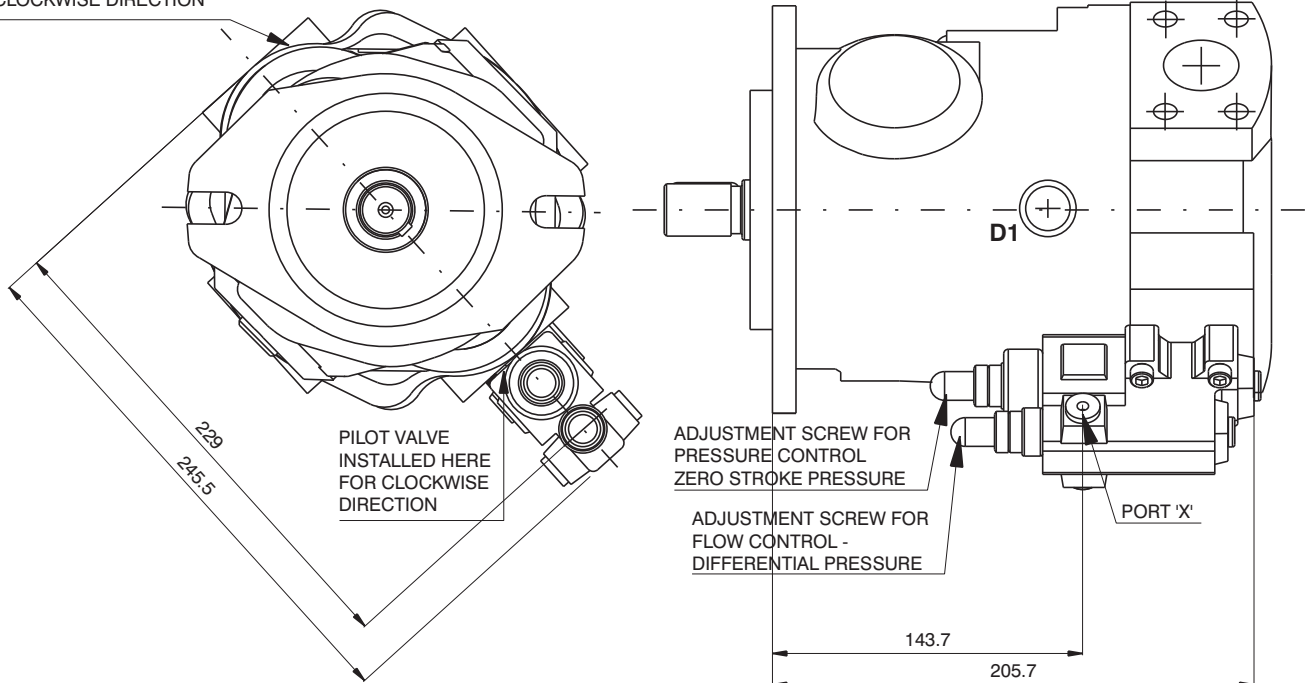

REAR PORTED :

ISO & SAE VERSIONS :

PILOT VALVE INSTALLED
HERE FOR COUNTER
CLOCKWISE DIRECTION

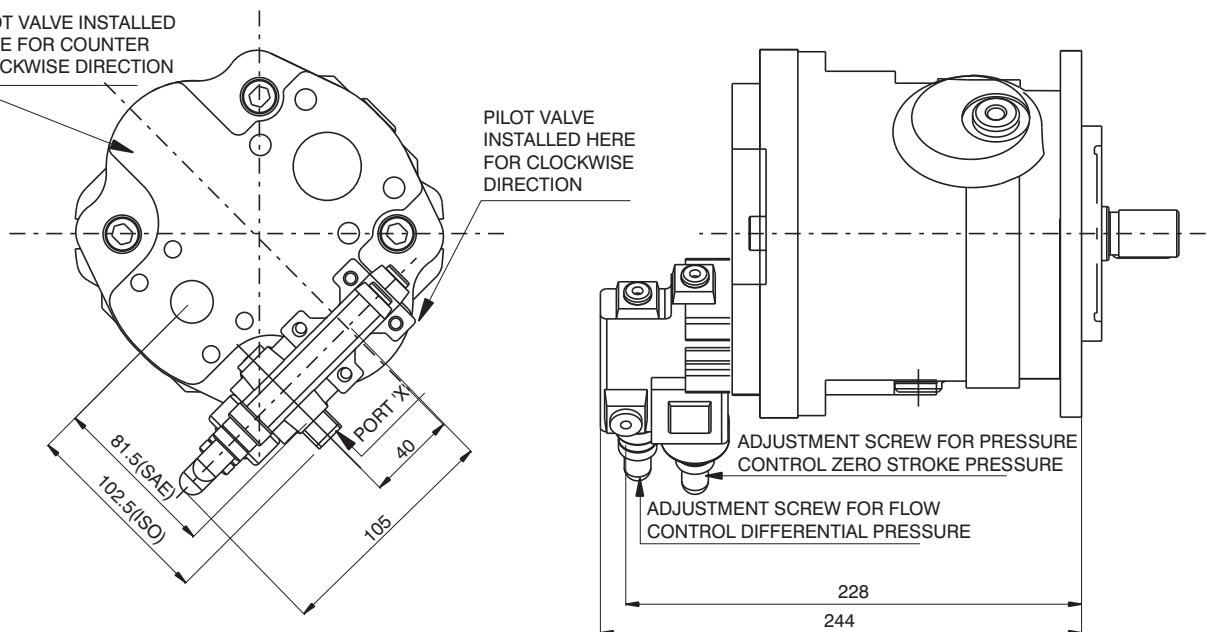

PORT 'X' DETAILS:-

ISO : M14x1.5 ; 12 DEPTH

SAE : 7/16 -20 UNF - 2B ; 10 DEPTH

PRESSURE, FLOW & POWER CONTROL (CPFH)

This control allows to limit the pump drive power at a constant speed (rpm) to set value in relation to the pump flow and pressure ($p \times v = \text{constant}$). Efficient power consumption is achieved with this and a constant drive torque is maintained with varying pressure and flows.

Operating pressure exerts a force on a piston within the control piston on to the swash plate. An externally adjustable spring force acts on the opposite side of this and this determines the power setting. When the force exerted by the operating pressure is more, the pilot control valve is operated, positioning the swash plate towards zero flow. When the pressure exerted by operating pressure is lower, the swash plate is positioned to give maximum flow. Here also it is possible to set the minimum and maximum angles of the swash plate by an external adjusting screw to limit the pump flow to 50% of it's maximum capacity.

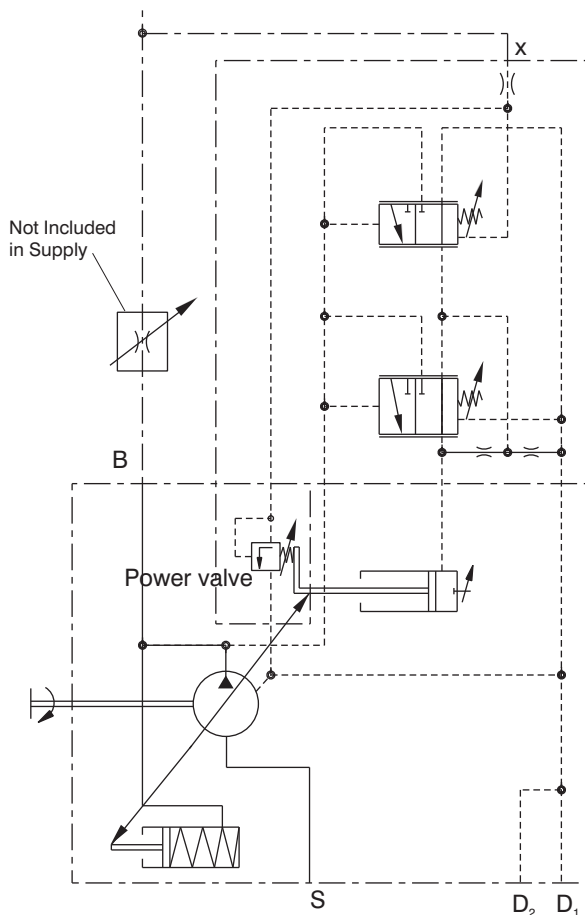

Ports

- B Outlet port
- S Inlet port
- D1,D2 Drain ports (D2 Plugged)
- X Pilot port

Requirement of pilot oil approx. 5.5 l/min (amx)

STATIC CURVE

At Speed 1500 rpm & temp. of oil at 50°C

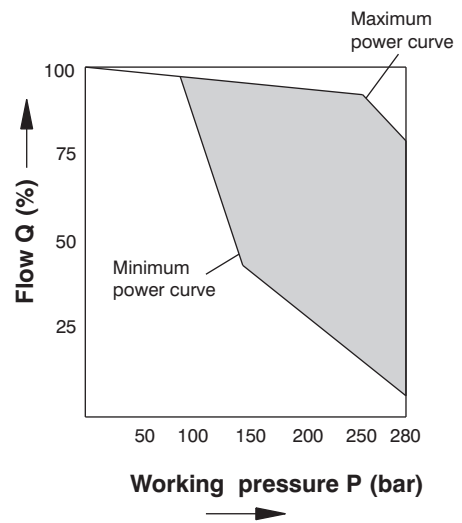

UNIT DIMENSIONS OF CPFH :

SIDE PORTED:

ISO & SAE VERSIONS:

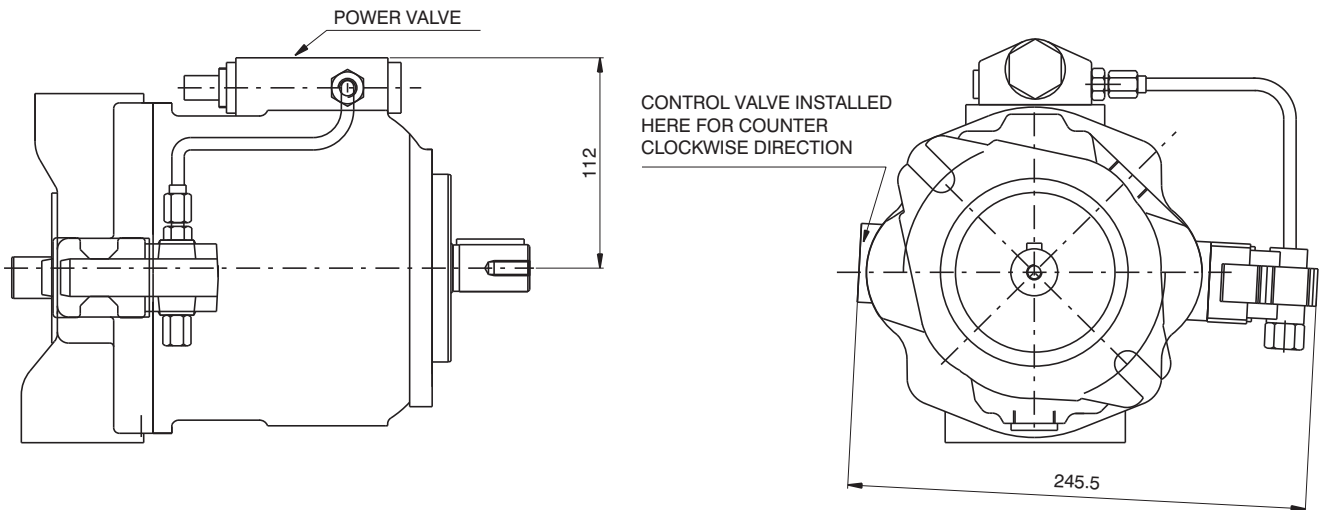

REAR PORTED:

ISO & SAE VERSIONS:

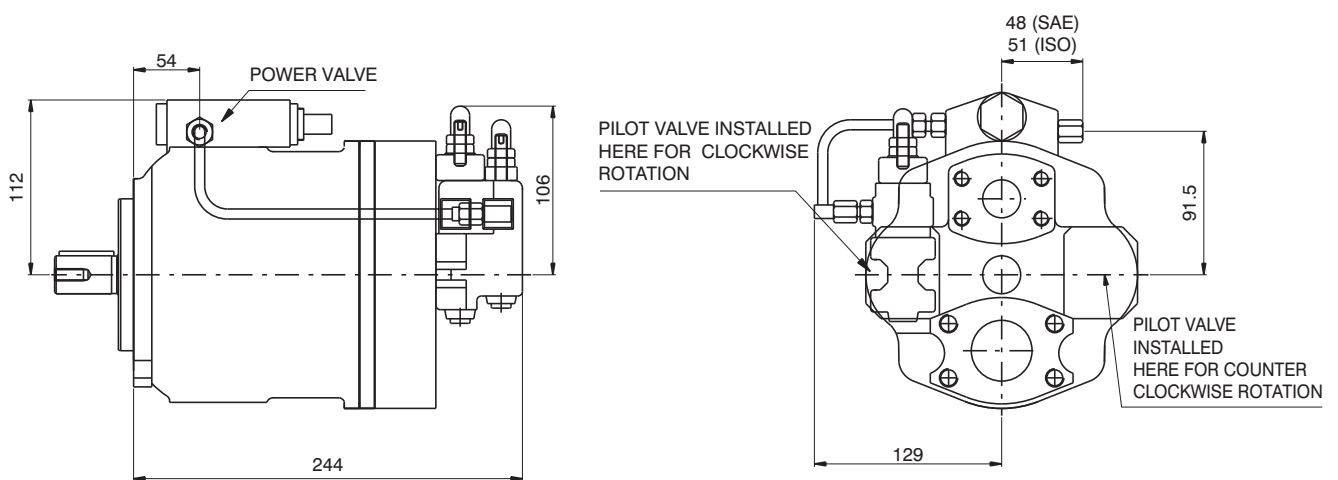

PORT X DETAILS:

ISO : M14x1.5, 12 DEPTH

SAE : 7/16" -20 UNF - 2B, 10 DEPTH