

J9V009

AXIAL PISTON PUMP

ORDERING CODE:

J **9** **V** **009** **CPR** **/** **R** **-** **N** **3** **B** **S2**

VELJAN

Axial piston pump

Variable displacement,

Swash plate design,

Working pressure 280 bar.

Peak pressure 350 bar.

Size

Displacement, Vgmax 9 cc/rev

Control devices

CP - Pressure control

CPR - Pressure control (Remote controlled)

CPFR - Pressure and flow control (X port closed)

Rotation

Viewed from shaft end

R - Clockwise

L - Counter clockwise

Seals

N: NBR- (Buna-N) gasket / Shaft seal FPM

Shaft end

1 - Keyed shaft (DIN 6885) Ø18

3 - Splined shaft 19-4 (SAE A-B, 3/4", 11 T)

2 - Keyed shaft 19-1(SAE) Ø19.05

4 - Splined shaft 16-4 (SAE A, 5/8", 9 T)

Mounting flange

A-ISO (2 bolt)

B-SAE (2 bolt)

Port connections

M2 - SAE rear ported, Metric threads

S2 - SAE rear ported, UNF threads

**UNIT DIMENSIONS OF J9V009
REAR PORTED (ISO & SAE VERSIONS)**

SHAFT END DETAILS:

SHAFT '1'

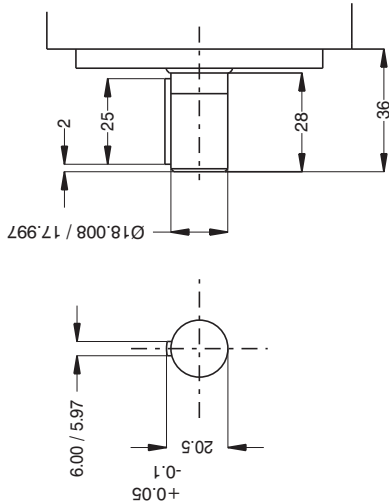

SHAFT '3'

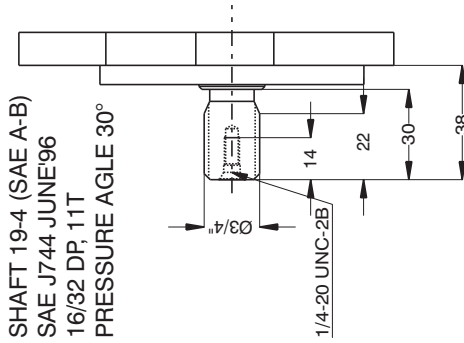

SHAFT '2'

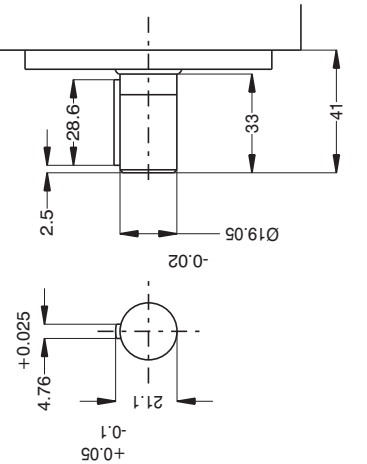

SHAFT '4'

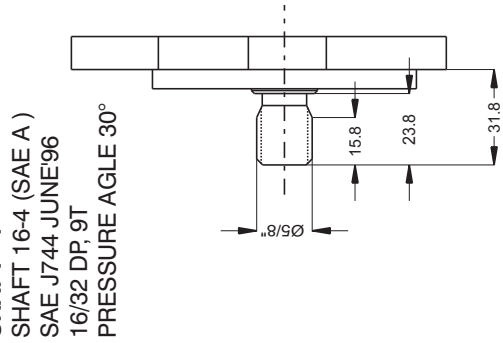

**TABLE 1
INLET / OUTLET PORTS:-**

VERSION	INLET PORT	OUTLET PORT
ISO	M27 x 2	M27 x 2
SAE	1 1/16 - 12 UNF - 2B	1 1/16 - 12 UNF - 2B

**TABLE 2
DRAIN PORTS:-**

VERSION	D1 CASE DRAIN PORT	D2 CASE DRAIN PORT (PLUGGED AT FACTORY)	X PILOT PORT
ISO	M16 x 1.5	M16 x 1.5	M14 x 1.5
SAE	9/16-18 UNF-2B	9/16-18 UNF-2B	7/16-20 UNF-2B

**TABLE 3
FLANGE DETAILS**

VERSION	IDENTIFICATION CODE	SPIGOT DIAMETER	SPIGOT LENGTH	PCD. OF HOLES
ISO	3019 / 2 2 BOLT FLANGE	Ø80.000 Ø79.954	7.0	Ø109
SAE	82-2(A) SAE J 744 JUN'96 2 BOLT FLANGE	Ø82.550 Ø82.496	6.4	Ø106.4

UNIT DIMENSIONS OF J9V 009 :
REAR PORTED (ISO & SAE VERSION)
 (NOT INCLUDING VALVES) :

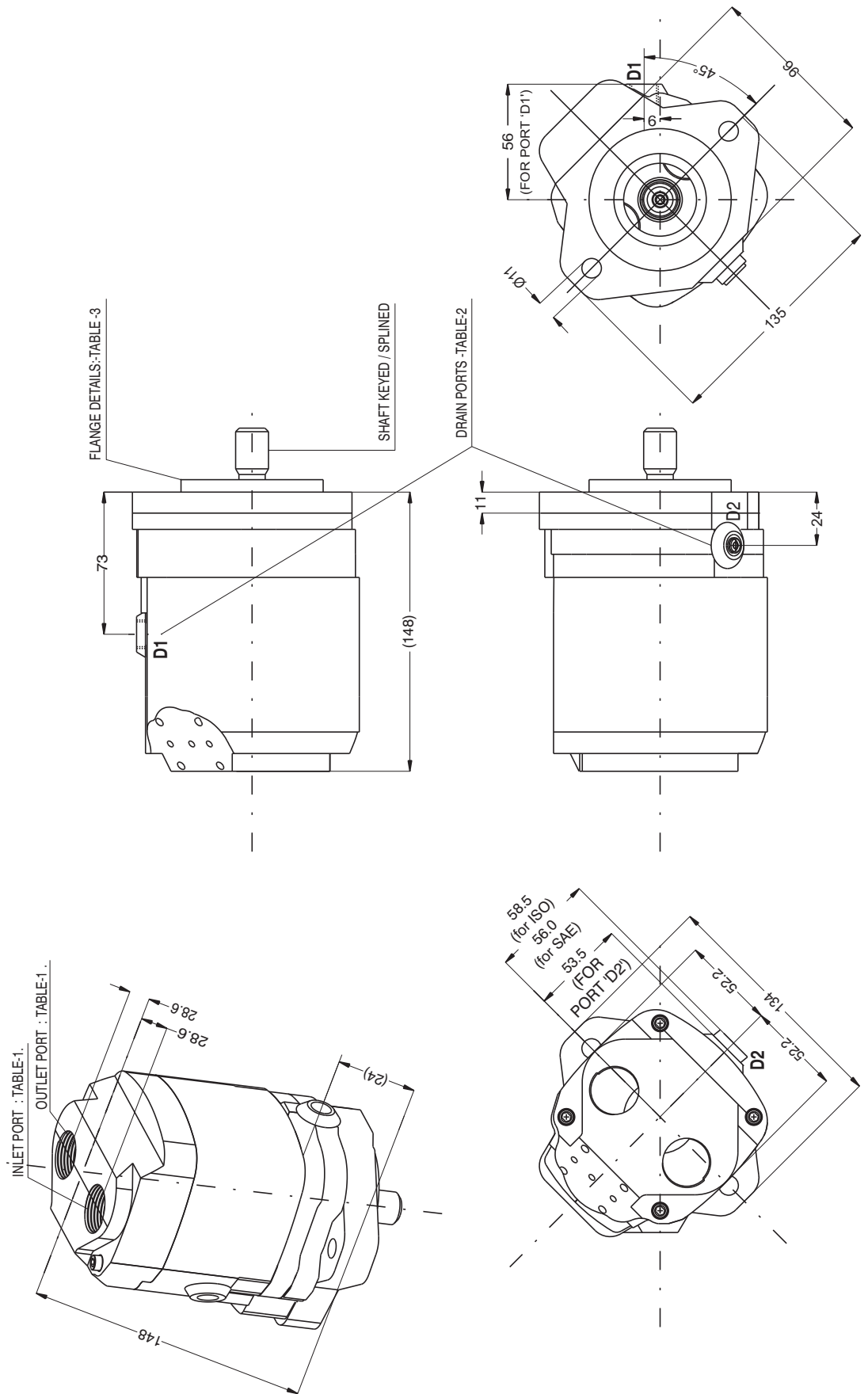

CONTROLS

The J9V 009 model piston pump is offered with a variety of control options that are designed for optimum performance of the pump in different types of applications.

CONSTANT PRESSURE CONTROL (CP)

This control maintains the pressure in a hydraulic circuit at a constant set value within the control range during pump operation irrespective of changing flow demands of the load on the pump. The pump supplies only that much volume of oil as required by the load. If the pressure in the circuit tends to raise above the set value, then the pump swash plate angle is proportionally reduced which in turn reduces the flow of oil to the load and thus preventing the pressure raise. In the starting condition when supply pressure is zero the control spring positions the swash plate at its maximum angle allowing the pump to supply the maximum volume of oil to the load in the circuit. As the pressure in circuit raises, the swash plate angle is progressively reduced by the control piston resulting in lesser oil flow to the circuit. It is further possible to restrict the min. and max. angles of the swash plate by adjustable set screws for limiting the pump flow to 50% of it's max. rating. As it is possible to set the pressure control at a pressure higher than the maximum rated pressure of the pump it is recommended that an additional pressure relief valve (set to about 20 bar more than the maximum allowed control pressure) be used in the circuit.

Also to ensure that the pressure control is not set for higher than the permissible value, help of a pressure gauge mounted on the pump outlet side be considered

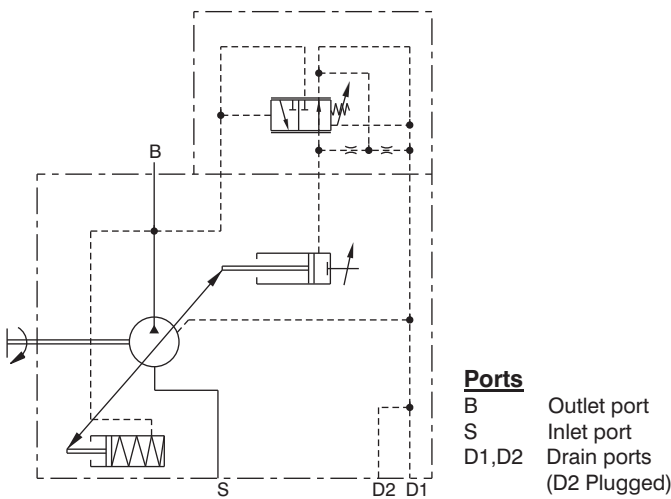

STATIC CURVE

At Speed 1500 rpm and Temperature of oil at 50° C

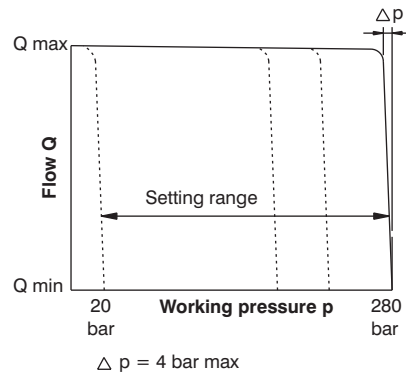

**UNIT DIMENSIONS OF CP :
REAR PORTED
ISO & SAE VERSIONS**

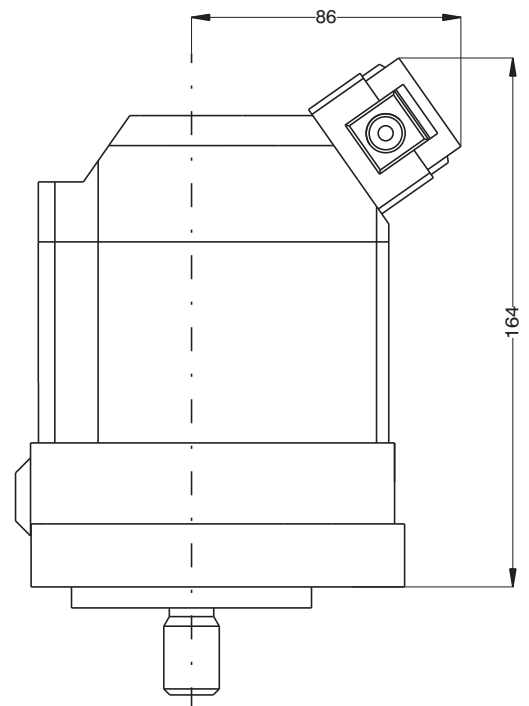
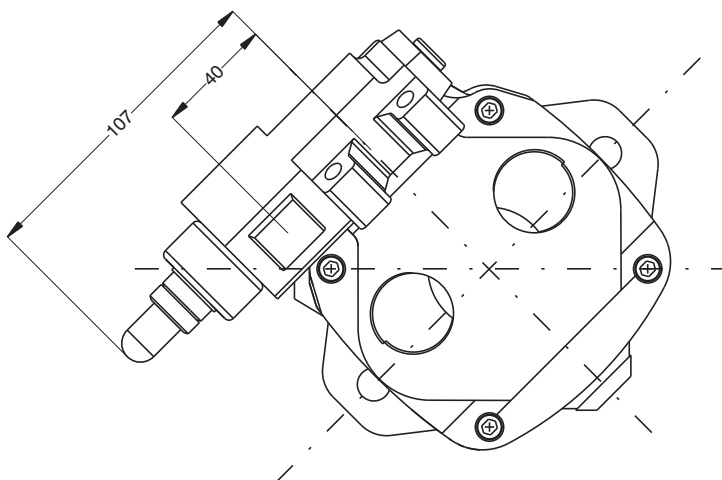

CONTROLS

CONSTANT PRESSURE CONTROL – REMOTELY SET (CPR)

This is same as above Constant Pressure Control except that in this a remotely mounted pressure relief valve is used as shown in the circuit along side for pressure setting of the pump.

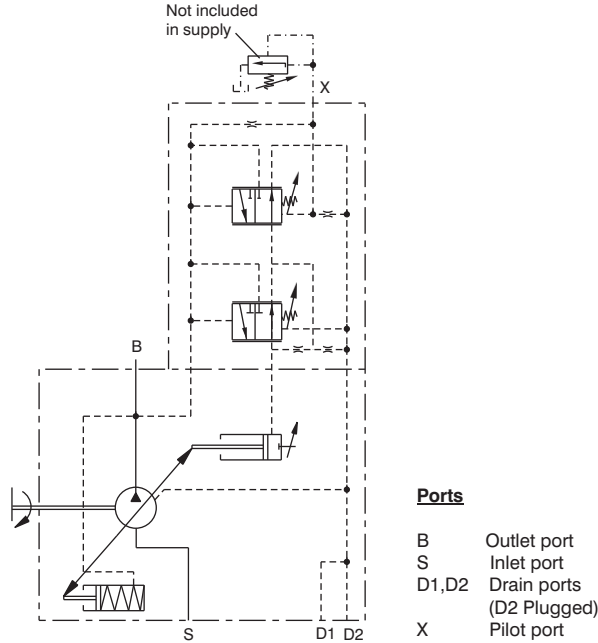

Requirement of pilot oil approx. 1.5 L/min (max) at 20 bar

STATIC CURVE

At Speed 1500 rpm and Temperature of oil at 50° C

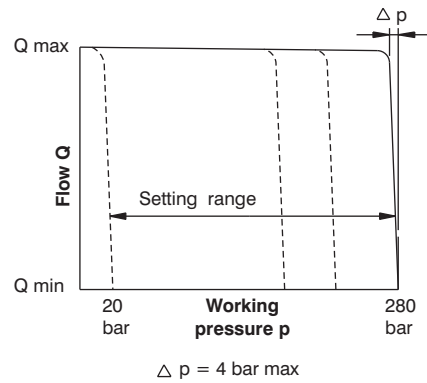

PRESSURE & FLOW CONTROL - X PORT CLOSED (CPFR) :

In addition to the constant pressure control this also maintains constant flow to the load. The pump flow is determined by an external orifice (not part of pump control block) fitted in the circuit between the pump and the load as long as the load pressure is less than the set pressure. The differential pressure at the external orifice is used to regulate the pump displacement to match the load requirement. The pressure drop across the orifice is maintained constant and there by achieving constant flow to the load. If the differential pressure across the orifice tends to increase then the swash plate is swivelled to minimum angle reducing the pump flow and if the pressure differential is reducing then the swash plate is swivelled to the maximum angle increasing the pump flow to load. These corrections go on continuously until a balance is restored at the flow control orifice

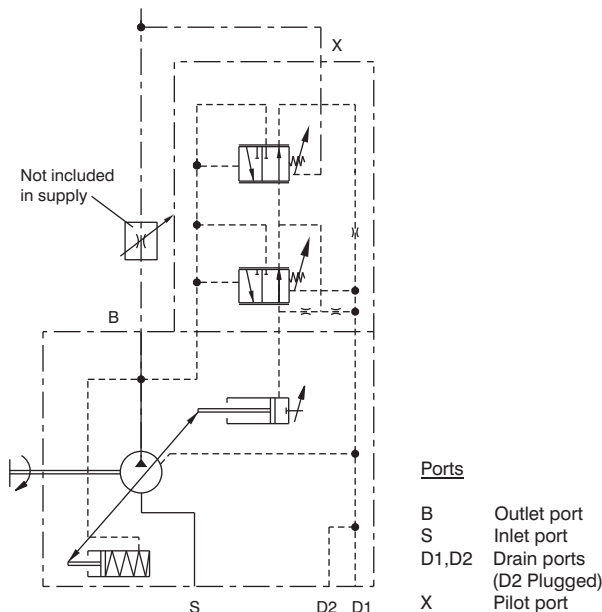

STATIC CURVE

At Speed 1500 rpm and Temperature of oil at 50° C

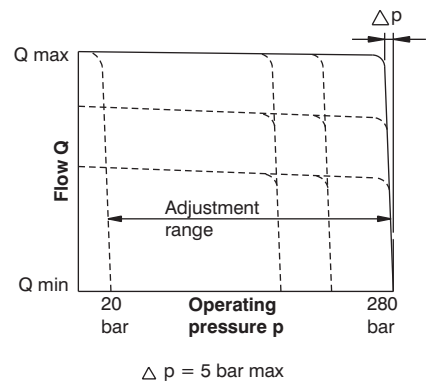

**UNIT DIMENSIONS OF CPR / CPFR :
REAR PORTED
ISO & SAE VERSIONS**

